

Revisions			
REV	ECN #	Description	Date
B	R20160015	1.Change soldertail height 0.02mm to 0.06mm; 2.Total stack height changed to 1.08mm; 3.Correct FPC pad position & enlarge pad size to 0.4x0.7mm; 4.Enlarge PCB solder pad size to 0.35x0.8mm.	05/09-2016
C	R20160021	1.Define FPC solder mask opening size; 2. Add the post; 3. Change flange height tolerance; 4.Optimize housing size; 5. Remove stiffener fillister .	06/24-2016
D	R20170002	Modified post height.	03/08-2017

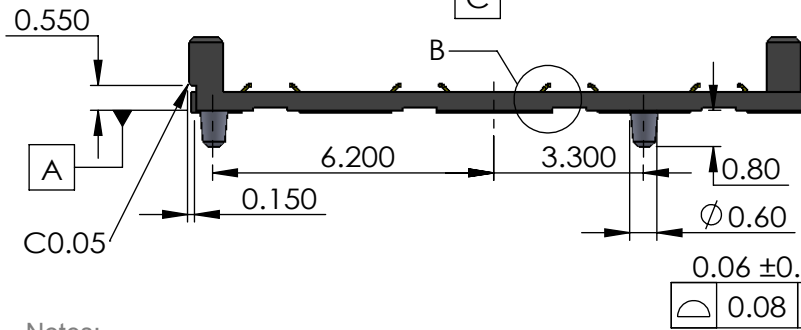

DETAIL B
SCALE 12 : 1

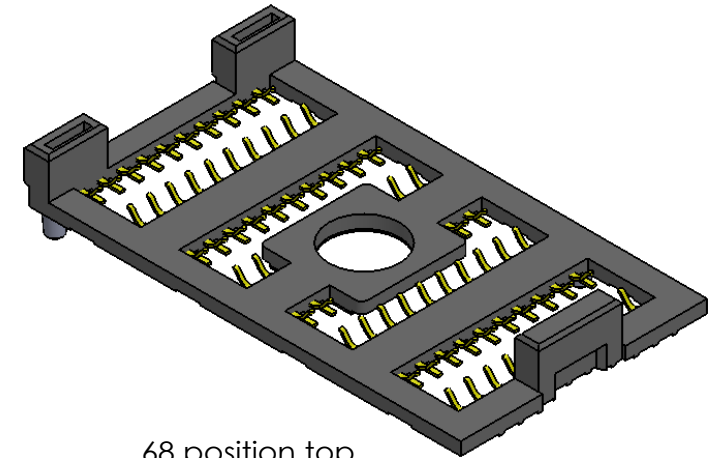
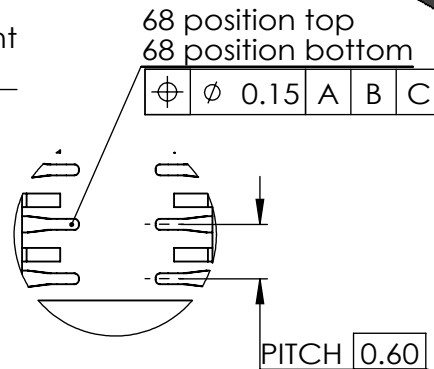

DETAIL A
SCALE 12 : 1

NCX P/N: XBM-D068A

Notes:

- Material:
Contacts: High performance copper alloy.
Housing: LCP resin, Glass fiber filled, UL94V-0 rated, black color.
Plating: 5 u" min gold plated on contact tip, gold flash on soldertail area, 70 ± 30 u" nickel underplated.
- This product compliants with European Union directives of RoHS requirements.
- The product can withstand exposure peak temperature 260C for 10 sec in SMT soldering process.
- Recommended stencil thickness no thinner than 0.1mm, solder past opening no less than pad size.

DIMENSIONS ARE IN mm
TOLERANCES (unless otherwise specified):

ANGULAR: ± 2 degree
LINEAR: .X ± 0.15
.XX ± 0.08
.XXX ± 0.04

MATERIAL	See note 1
FINISH	gold

	NAME	DATE
DRAWN	Huangwei	05/09-2016
CHECKED	Jason Wu	05/09-2016
Appr	Gary Hsieh	05/09-2016
Release level	Preliminary	
COMMENTS:	DO NOT SCALE DRAWING	

聯能科技 Unimicron Group			
Title: 68 pos X-Beam interposer (0.6 mm pitch, M2.0 screw)			
projection	SIZE A	DWG. NO. XBGUAW001	REV. D
SCALE:5:1	WEIGHT:	SHEET 1 OF 5	

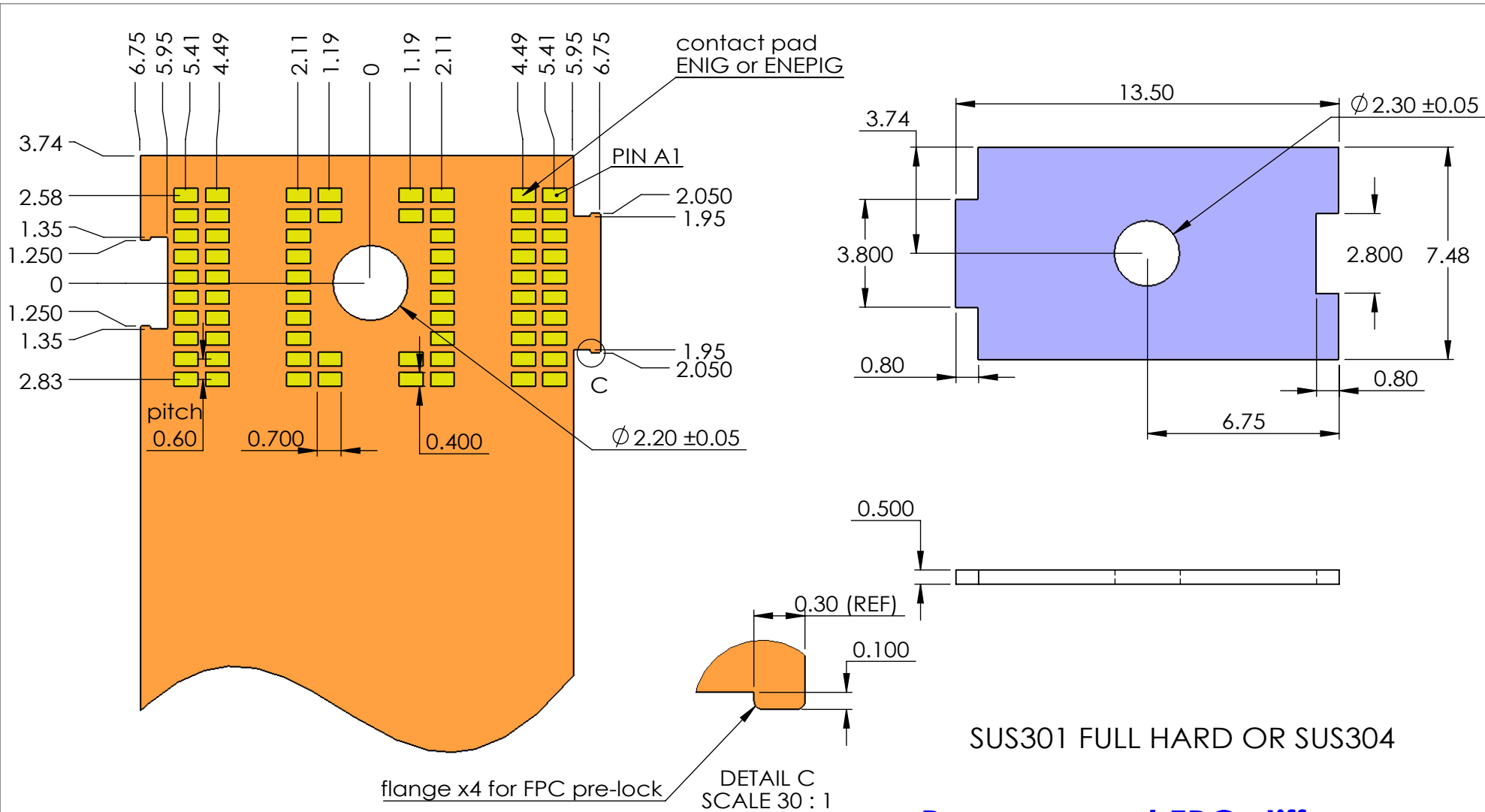

Recommend FPC footprint

- Note:
1. The stiffener is to align with connector housing when final assembly.
 2. The alignment tolerance for FPC & stiffener is ± 0.075 mm. Based on left notch (1.250+1.250)&right protrusion (2.050+2.050) feature.
 3. Solder mask opening min: 0.50 x 0.80 mm min.

Recommend FPC stiffener

NCX P/N: XBM-D068A

SUS301 FULL HARD OR SUS304

DIMENSIONS ARE IN mm
TOLERANCES (unless otherwise specified):

ANGULAR: ± 2 degree
LINEAR: .X ± 0.15
.XX ± 0.08
.XXX ± 0.04

聯能科技 Unimicron Group

Title:
68 pos X-Beam interposer
(0.6 mm pitch, M2.0 screw)

SIZE	A	DWG. NO. XBGUAW001	REV. D
SCALE:5:1		WEIGHT:	SHEET 2 OF 5

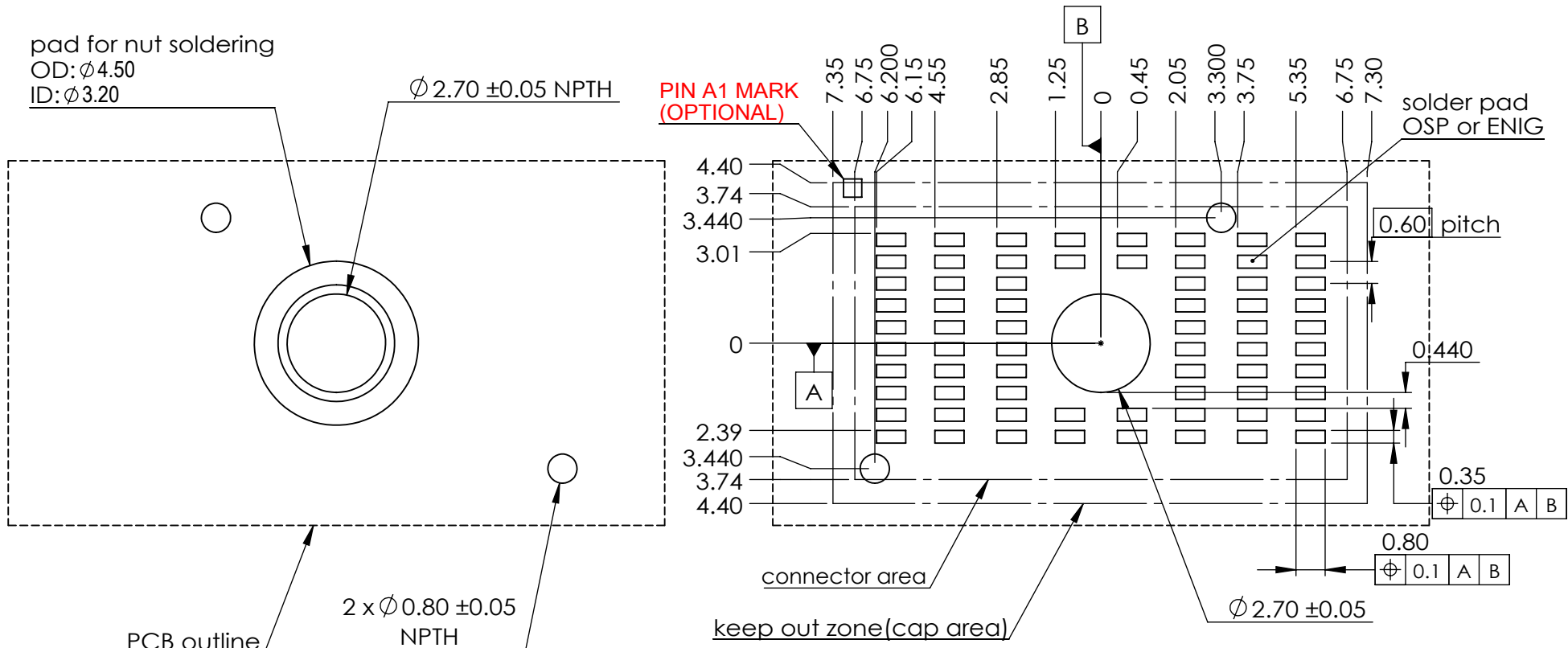

Max S/M THK 35um above pad surface

Back side

Front side

Recommend PCB footprint

NCX P/N: XBM-D068A

DIMENSIONS ARE IN mm
 TOLERANCES (unless otherwise specified):

ANGULAR: ± 2 degree
 LINEAR: .X ± 0.15
 .XX ± 0.08
 .XXX ± 0.04

聯能科技 Unimicron Group

Title:
 68 pos X-Beam interposer
 (0.6 mm pitch, M2.0 screw)

SIZE A	DWG. NO. XBGUAW001	REV. D
SCALE:5:1	WEIGHT:	SHEET 3 OF 5

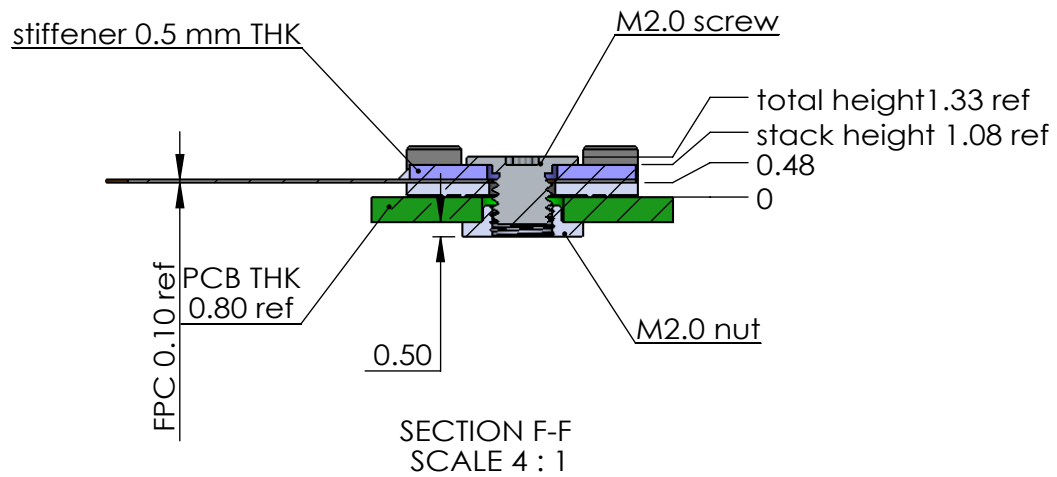
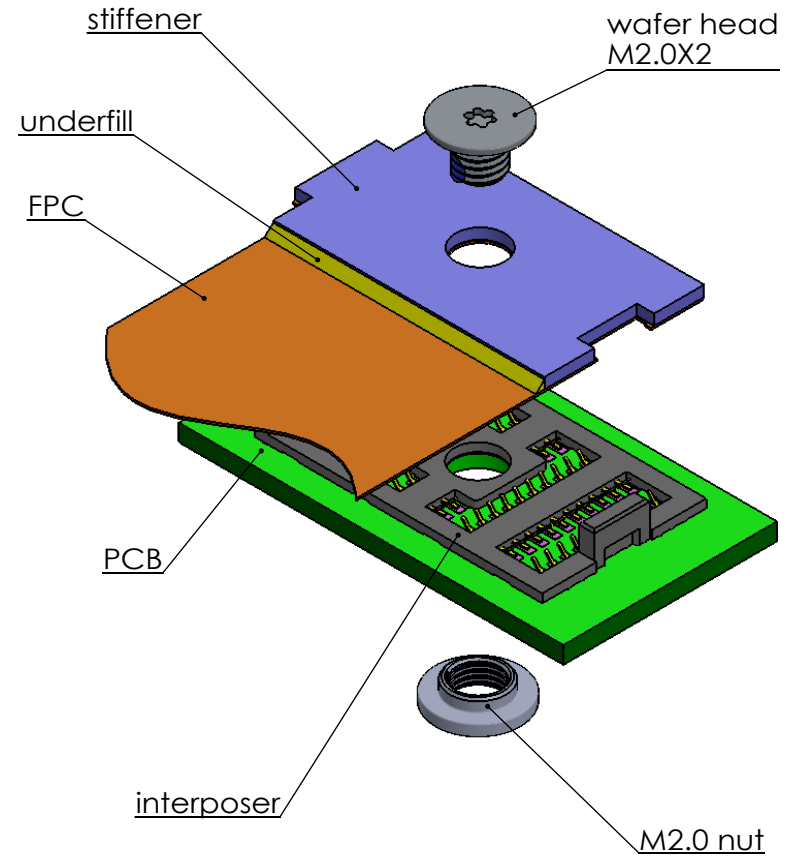
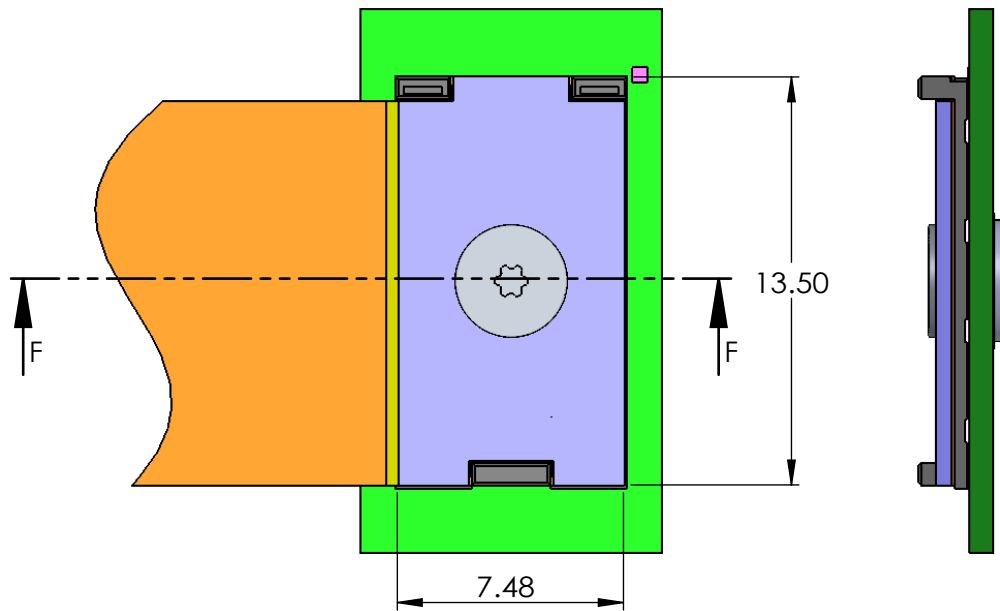

NCX P/N: XBM-D068A

聯能科技 Unimicron Group

Title:
68 pos X-Beam interposer
(0.6 mm pitch, M2.0 screw)

SIZE	A	DWG. NO. XBGUAW001	REV. D
SCALE:5:1		WEIGHT:	SHEET 4 OF 5

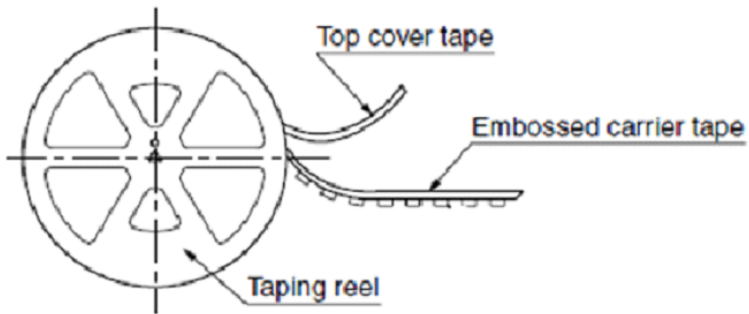

SMT

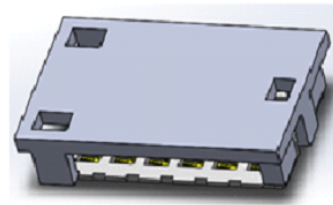
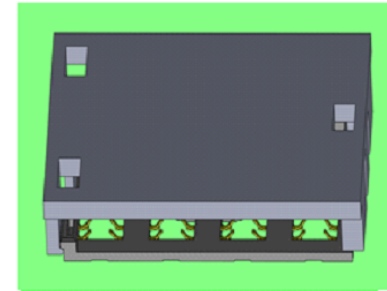

Connector with cap

Remove cap
before FPC
assy

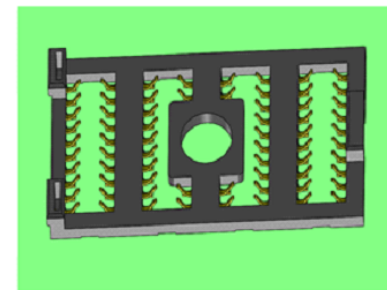

- Tape & reel or tray package for auto-SMT process on board.

Place FPC &
screw lock

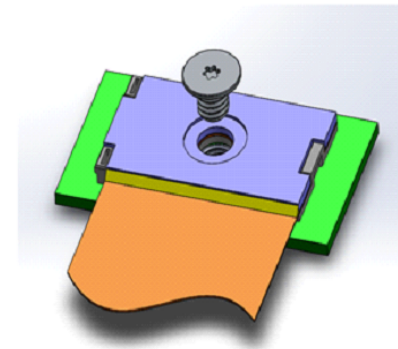

package and assembly process

NCX P/N: XBM-D068A

聯能科技 Unimicron Group

Title:
68 pos X-Beam interposer
(0.6 mm pitch, M2.0 screw)

SIZE	A	DWG. NO. XBGUAW001	REV. D
SCALE:5:1		WEIGHT:	SHEET 5 OF 5