

- PROPRIETARY INFORMATION -  
NO USE OR REPRODUCTION MAY BE MADE OF  
THIS DOCUMENT WITHOUT EXPRESS WRITTEN  
PERMISSION OF NEOCONIX.

REVISION				
REV	ECN	DESCRIPTION	DATE	DESIGN BY
1	0000	INITIAL RELEASE	03-01-2023	TAN N

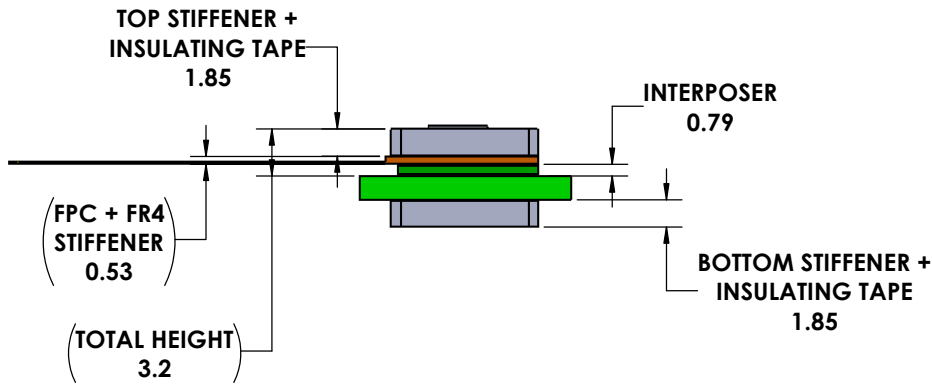
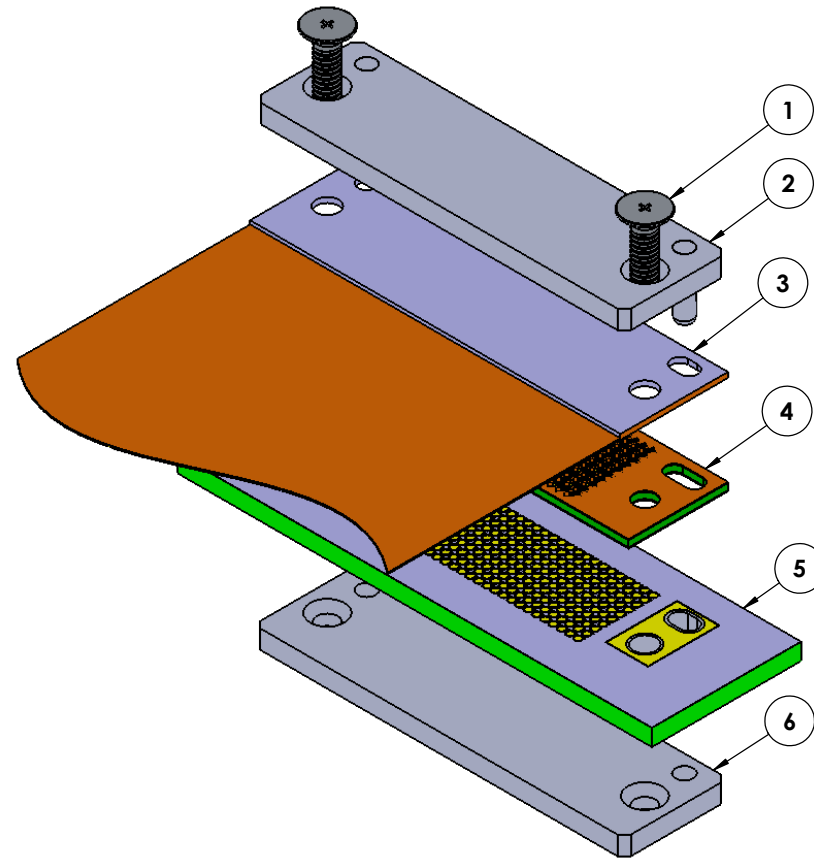
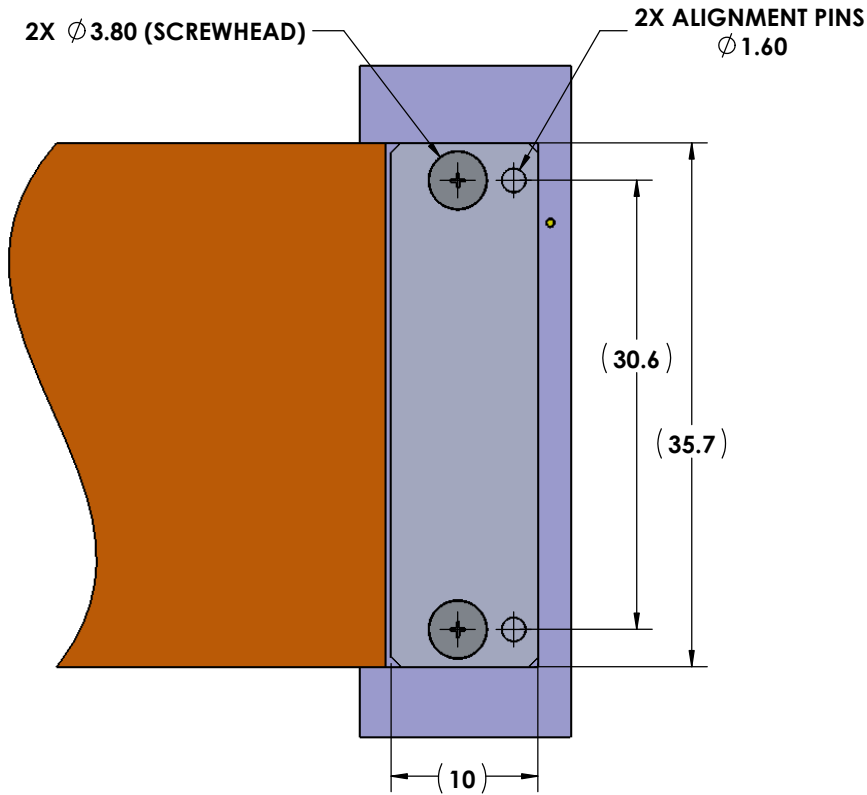

ITEM	DESCRIPTION	NEOCONIX P/N	QTY PER ASSY
1	M2 FLATHEAD SCREW	VARIOUS *	2
2	TOP STIFFENER	<b>B01-000840-LXXX*</b>	1
3	FPC	CUSTOM UPON REQUEST	1
4	INTERPOSER	<b>SPH2-MC300A</b>	1
5	PCB	N/A - CUSTOMER SUPPLIED	1
6	BOTTOM STIFFENER	<b>B01-000628</b>	1

**\* SEE AS-000034 FOR VARIOUS PART NUMBER  
OPTIONS BASED ON ASSEMBLY THICKNESS STACKUP.  
ALL ITEMS ORDERED SEPARATELY.**

<p>4020 MOORPARK AVENUE #108 SAN JOSE, CA 95117 USA TEL: 408-530-9393 FAX: 408-530-9383</p>	DIMENSIONS ARE IN MM [INCH] .X ± .XX ± .XXX ± ANGLE: NO DEC ± .X ± .XX ±	MATERIAL: SEE NOTES FINISH: <input checked="" type="checkbox"/>	TITLE: <b>SPH2 ASSEMBLY 300 POSITIONS LGA-LGA</b>	
	DRAWN BY: TAN NGUYEN CHECKED BY: FRED HOOPER	03-01-2023 03-01-2023	SIZE: <b>B+</b>	DWG NUMBER: <b>SPH2-MC300A-ASY</b>
	ENGR APPR: MFG APPR: QA APPR:			REV: <b>1</b>
	THIRD ANGLE			SCALE: 3:1 SHEET 1 OF 4

- PROPRIETARY INFORMATION -  
NO USE OR REPRODUCTION MAY BE MADE OF  
THIS DOCUMENT WITHOUT EXPRESS WRITTEN  
PERMISSION OF NEOCONIX.

REVISION				
REV	ECN	DESCRIPTION	DATE	DESIGN BY
1	0000	INITIAL RELEASE	03-01-2023	TAN N

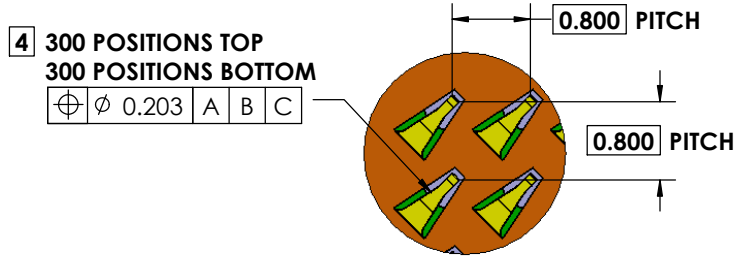

**DETAIL A**

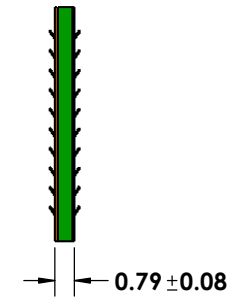
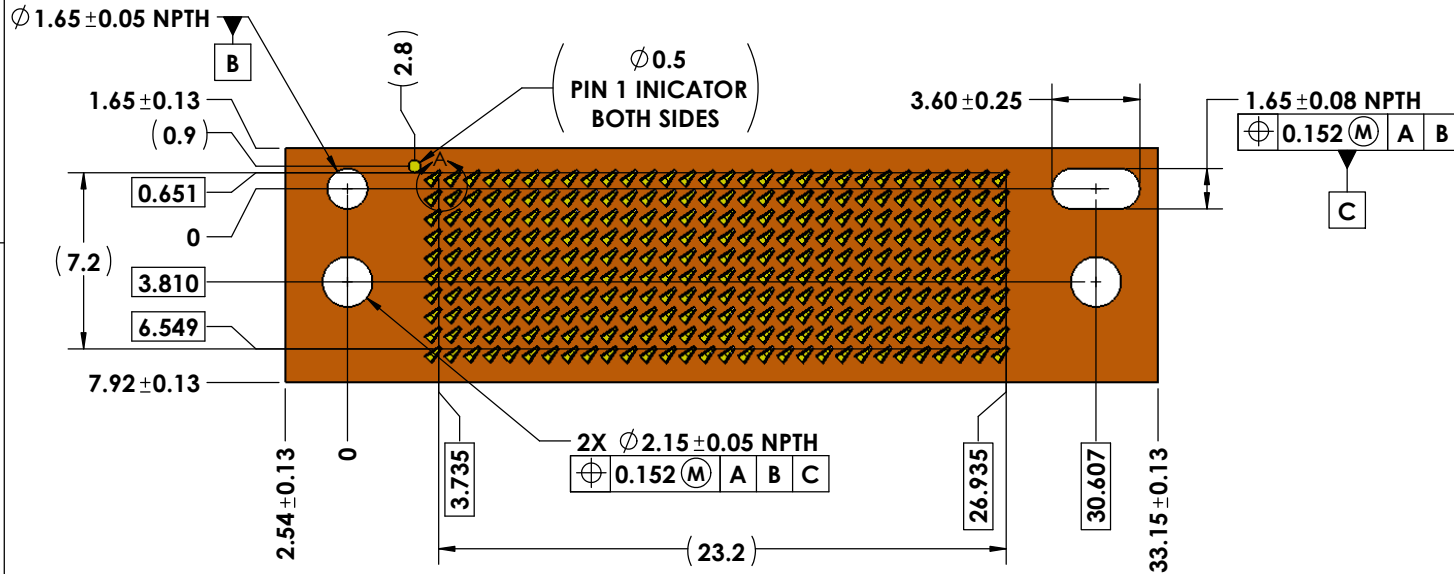
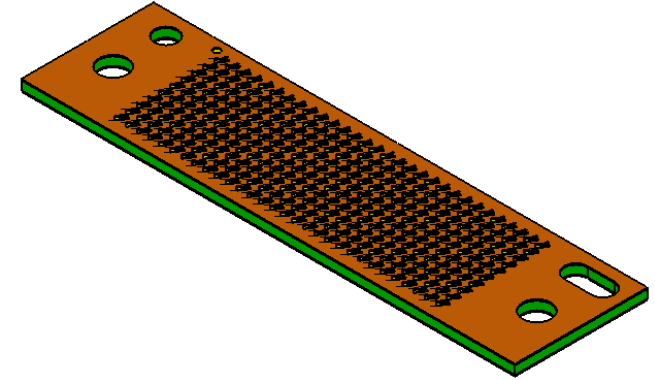

**COMPRESSED**

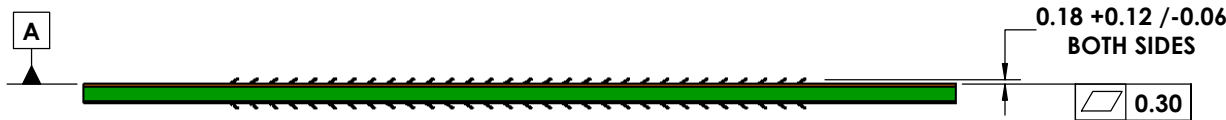

**UNCOMPRESSED**

**NOTES (UNLESS OTHERWISE SPECIFIED):**

1. INTERPRET DRAWING PER ASME Y14.5M-1994.
2. HALOGEN-FREE PER IPC-4101B.
3. COMPLIANT WITH RoHS DIRECTIVE 2011/65/EU.

**4** CENTER MARKS OF CONTACT POSITIONS ARE FOR COMPRESSED STATE.

<p>4020 MOORPARK AVENUE #108 SAN JOSE, CA 95117 USA TEL: 408-530-9393 FAX: 408-530-9383</p>	DIMENSIONS ARE IN MM [INCH] .X ±0.13 .XX ±0.08 .XXX ±0.025 ANGLE: NO DEC+2 DEGREE .X ± .XX ±	MATERIAL: <b>SEE NOTES</b> FINISH:	TITLE: <b>SPH2 INTERPOSER 300 POS LGA-LGA</b>	
	DRAWN BY: <b>TAN NGUYEN</b> 03-01-2023 CHECKED BY: <b>FRED HOOPER</b> 03-01-2023	ENGR APPR: MFG APPR: QA APPR:	SIZE: <b>B+</b> DWG NUMBER: <b>SPH2-MC300A</b>	REV: <b>1</b>
	THIRD ANGLE	SCALE: 5:1	SHEET 2 OF 4	

REVISION				
REV	ECN	DESCRIPTION	DATE	DESIGN BY
1	0000	INITIAL RELEASE	03-01-2023	TAN N

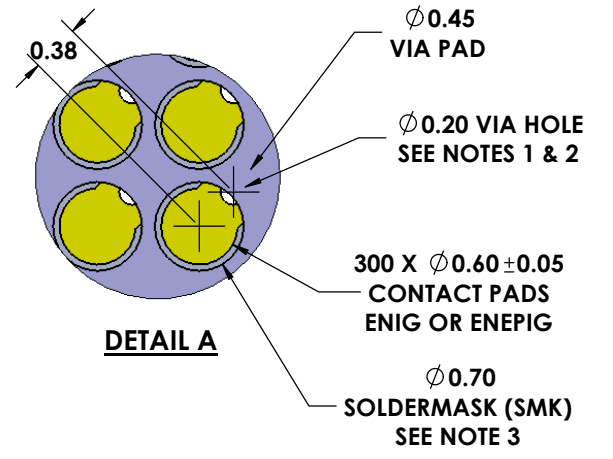
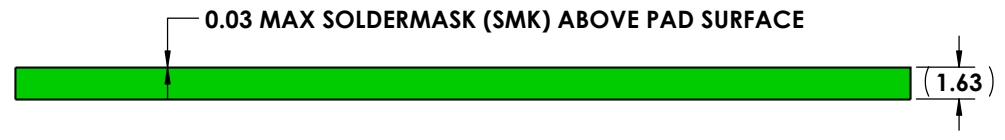
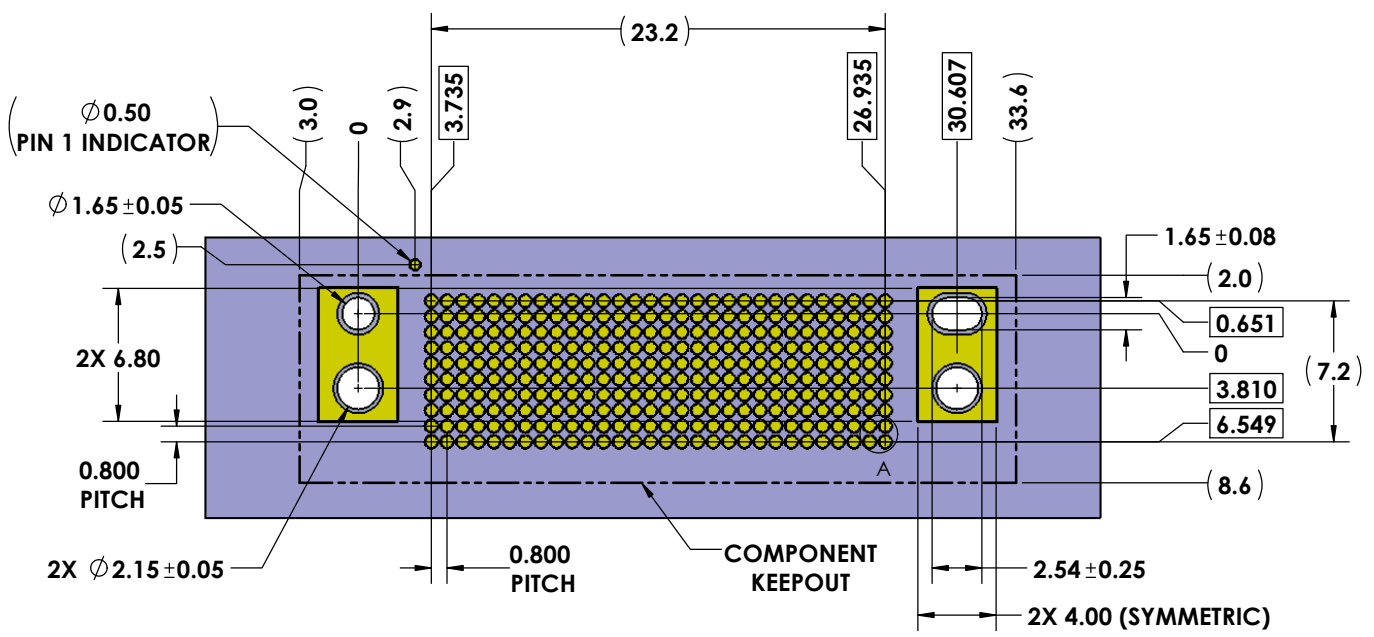

**NOTES:**

- IT IS ACCEPTABLE TO ROTATE THE POSITION OF THE VIAS AS NEEDED.
- IF THE VIA NEEDS TO BE LOCATED WITHIN THE 0.60MM PAD DIAMETER, IT MUST BE FILLED, PLATED, AND PLANARIZED WITH 25UM MAX DIMPLE.
- SOLDERMASK APPLICATION IN THE ARRAY AREA IS OPTIONAL. IF APPLIED, IT SHALL NOT PROTRUDE MORE THAN 0.03MM ABOVE THE SURFACE OF THE MATING PADS.



 4020 MOORPARK AVENUE #108 SAN JOSE, CA 95117 USA TEL: 408-530-9393 FAX: 408-530-9383	DIMENSIONS ARE IN MM [INCH]	MATERIAL: <b>SEE NOTES</b>	TITLE: <b>RECOMMENDED PCB LAYOUT                  SPH2-MC300A</b>
	FINISH:	DRAWN BY: <b>TAN NGUYEN</b> 02-01-2023	SIZE: <b>B+</b>
CHECKED BY: <b>FRED HOOPER</b> 03-01-2023	ENGR APPR:	DWG NUMBER: <b>SPH2-MC300A-PCB</b>	REV <b>1</b>
MFG APPR:	QA APPR:	SCALE: 4:1	SHEET 3 OF 4

- PROPRIETARY INFORMATION -  
NO USE OR REPRODUCTION MAY BE MADE OF  
THIS DOCUMENT WITHOUT EXPRESS WRITTEN  
PERMISSION OF NEOCONIX.

REVISION				
REV	ECN	DESCRIPTION	DATE	DESIGN BY
1	0000	INITIAL RELEASE	03-01-2023	TAN N

**NOTES:**

1. IT IS ACCEPTABLE TO ROTATE THE POSITION OF THE VIAS AS NEEDED.
2. IF THE VIA NEEDS TO BE LOCATED WITHIN THE 0.60MM PAD DIAMETER, IT MUST BE FILLED, PLATED, AND PLANARIZED WITH 25UM MAX DIMPLE.
3. SOLDERMASK APPLICATION IN THE ARRAY AREA IS OPTIONAL. IF APPLIED, IT SHALL NOT PROTRUDE MORE THAN 0.03MM ABOVE THE SURFACE OF THE MATING PADS.

 <b>4020 MOORPARK AVENUE #108</b> <b>SAN JOSE, CA 95117 USA</b> <b>TEL: 408-530-9393 FAX: 408-530-9383</b>	DIMENSIONS ARE IN MM [INCH] .X ± .XX ± .XXX ± ANGLE: NO DEC ± .X ± .XX ±	MATERIAL: <b>SEE NOTES</b> FINISH:	TITLE: <b>RECOMMENDED FPC LAYOUT</b> <b>SPH2-MC300A</b>	
		DRAWN BY: <b>TAN NGUYEN</b> 03-01-2023 CHECKED BY: <b>FRED HOOPER</b> 03-01-2023 ENGR APPR: MFG APPR: QA APPR:	SIZE: <b>B+</b> DWG NUMBER: <b>SPH2-MC300A-FPC</b>	REV: <b>1</b>
	SCALE: 4:1		SHEET 4 OF 4	