

- PROPRIETARY INFORMATION -
NO USE OR REPRODUCTION MAY BE MADE OF
THIS DOCUMENT WITHOUT EXPRESS WRITTEN
PERMISSION OF UNIMICRON.

Revisions			
REV	ECN #	Description	Date
1		Preliminary	08/24-2021

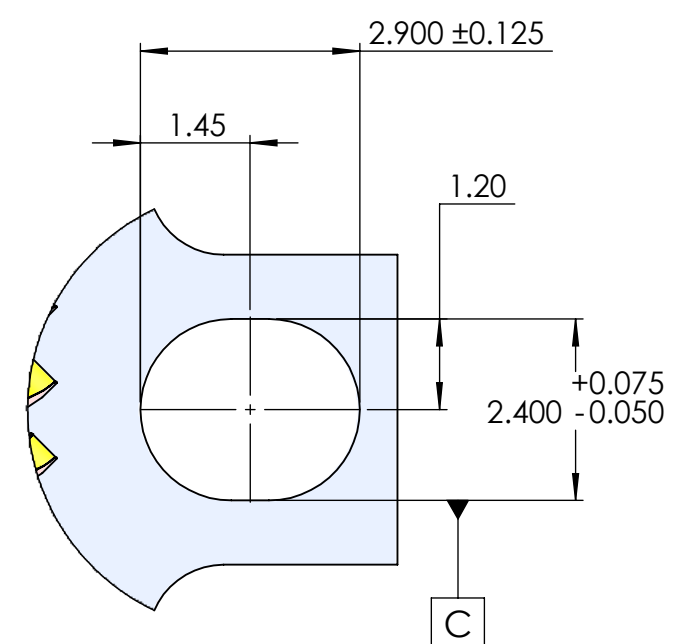

DETAIL A
SCALE 10 : 1

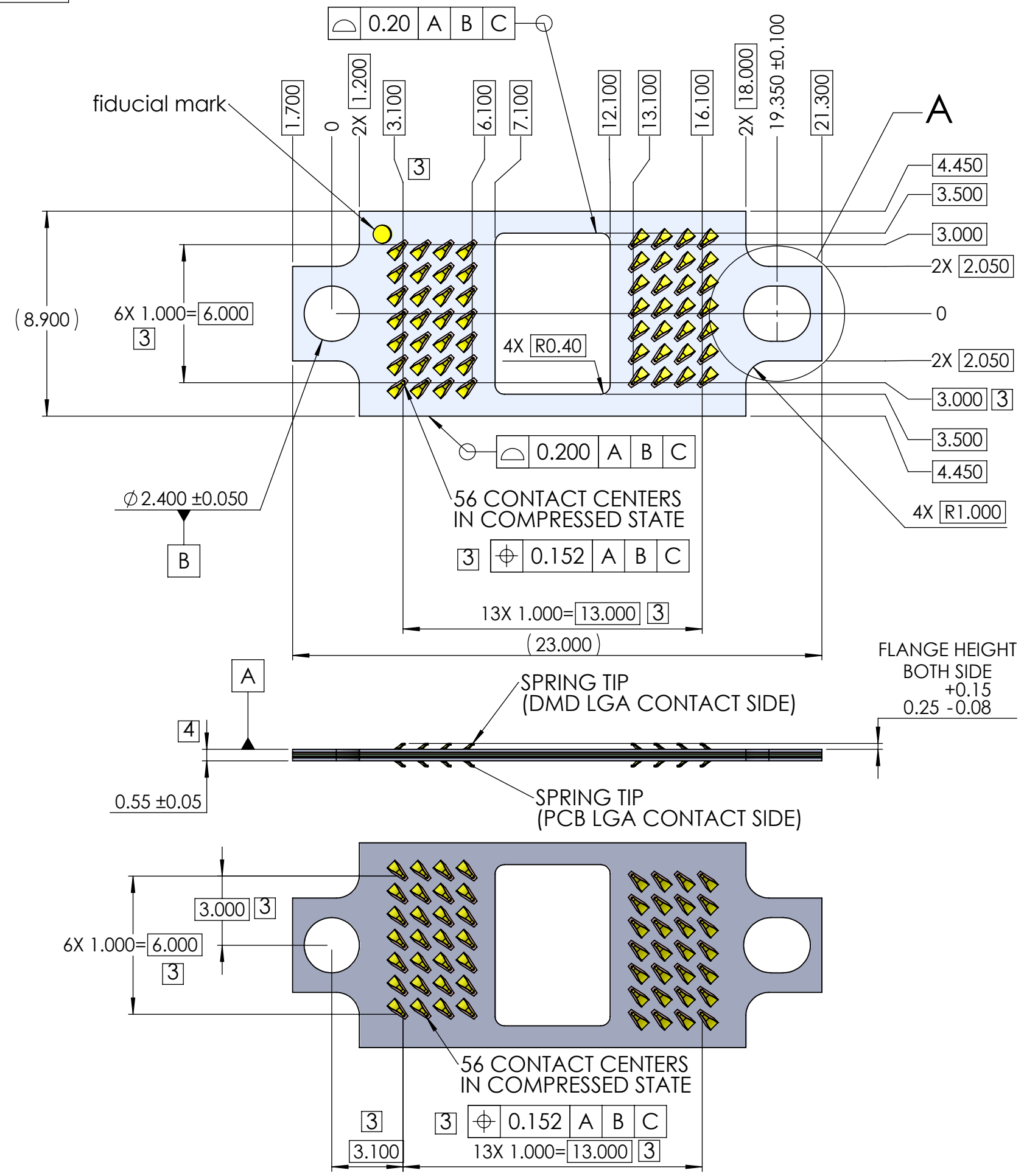
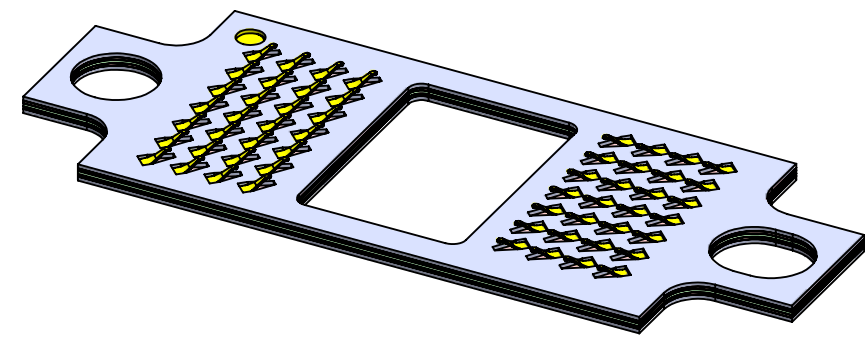

NOTES (UNLESS OTHERWISE SPECIFIED):

1. INTERPRET DRAWING PER ASME Y14.5M-95
2. COMPLIANT WITH ROHS DIRECTIVE 2011/65/EU
- 3 CENTER POSITION OF THE CONTACT AREA IN THE COMPRESSED STATE
- 4 HEIGHT WHEN CONTACTS ARE FULLY COMPRESSED BETWEEN DMD AND PCB

LLGUA9021A

	DIMENSIONS ARE IN MM		MATERIAL:		TITLE:	
	.X ± 0.15	.XX ± 0.10	FINISH: --		Interposer , LGA/LGA 56 POS Low-Height	
	.XXX ± 0.05	ANGLE: NO DEC ± 1°	DRAWN BY: Jianyu	08/24/2021	SIZE:	B+
	.X ± 0.5°	.XX ± 0.25°	CHECKED BY: Gary Hsieh	08/24/2021	DWG NUMBER: BDX0056DMM SXAU01	
THIRD ANGLE		ENGR APPR: Gary Hsieh	08/24/2021	REV 1		
		MFG APPR:			SCALE: 5:1 SHEET 1 OF 3	
		QA APPR:				

- PROPRIETARY INFORMATION -
NO USE OR REPRODUCTION MAY BE MADE OF
THIS DOCUMENT WITHOUT EXPRESS WRITTEN
PERMISSION OF UNIMICRON.

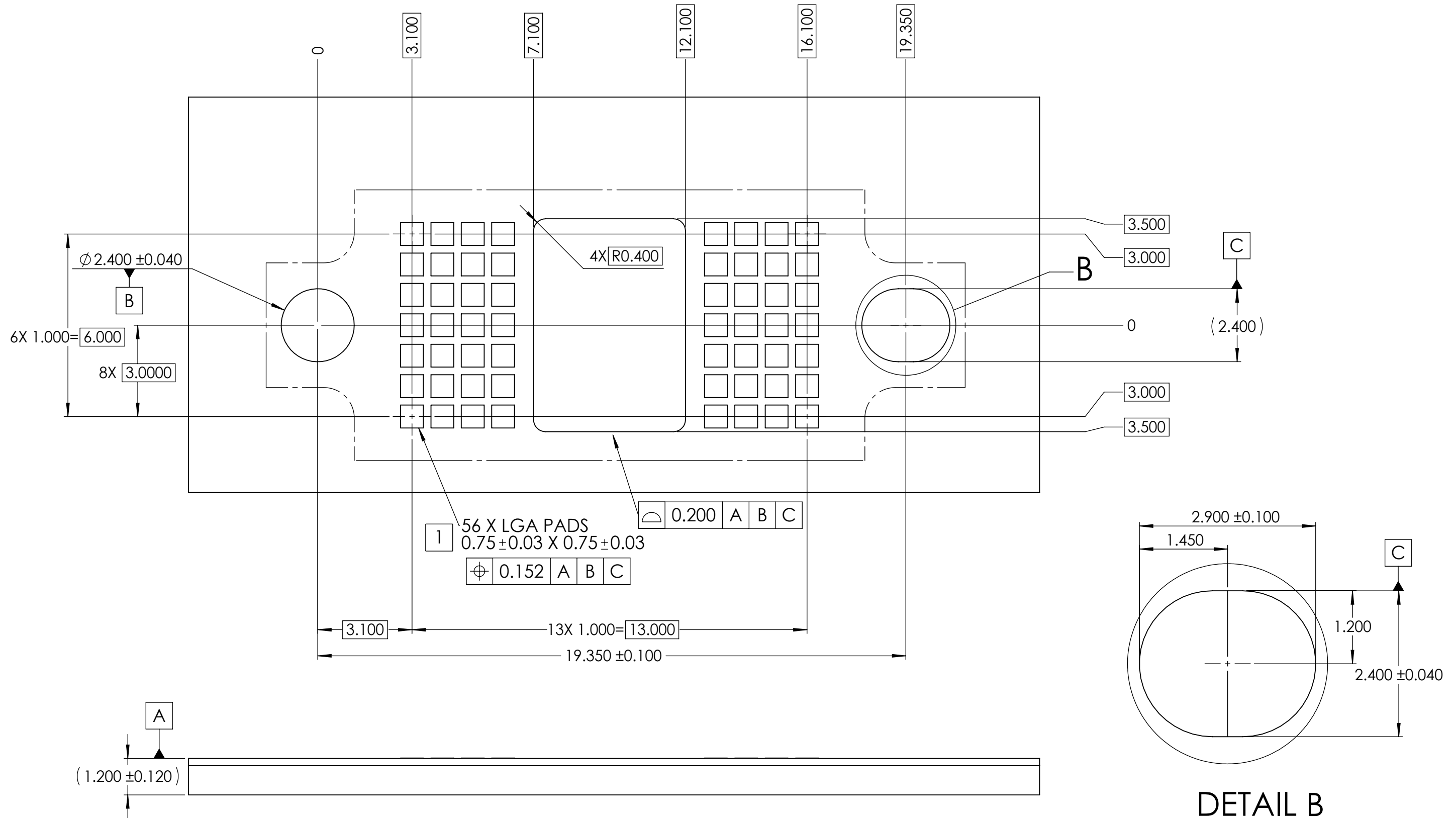

Recommended PCB PAD Layout

NOTES (UNLESS OTHERWISE SPECIFIED):

1 PADS TO BE ELECTROLESS

NICKEL / IMMERSION GOLD (ENIG)

PLATED.

	DIMENSIONS ARE IN MM .X ± 0.15 .XX ± 0.10 .XXX ± 0.05 ANGLE: NO DEC ± 1° .X ± 0.5° .XX ± 0.25°		MATERIAL: FINISH: --		TITLE: Interposer , LGA/LGA 56 POS LOW -Height	
	DRAWN BY: Jianyu 08/24/2021		CHECKED BY: Gary Hsieh 08/24/2021		SIZE: B+	
ENGR APPR: Gary Hsieh 08/24/2021		MFG APPR:		DWG NUMBER: BDX0056DMMSXAU01		
QA APPR:		SCALE: 5:1		SHEET 2 OF 3		

REV 1

- PROPRIETARY INFORMATION -
NO USE OR REPRODUCTION MAY BE MADE OF
THIS DOCUMENT WITHOUT EXPRESS WRITTEN
PERMISSION OF NEOCONIX.

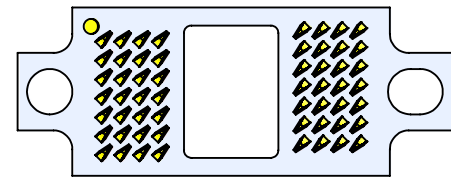

50PCS/TRAY

CARTON LABELS

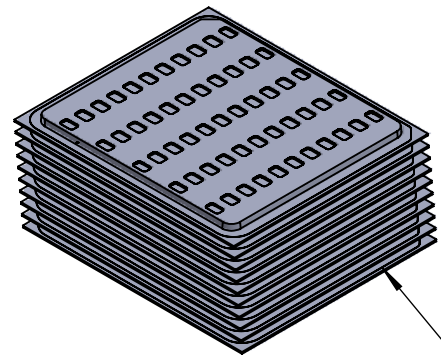
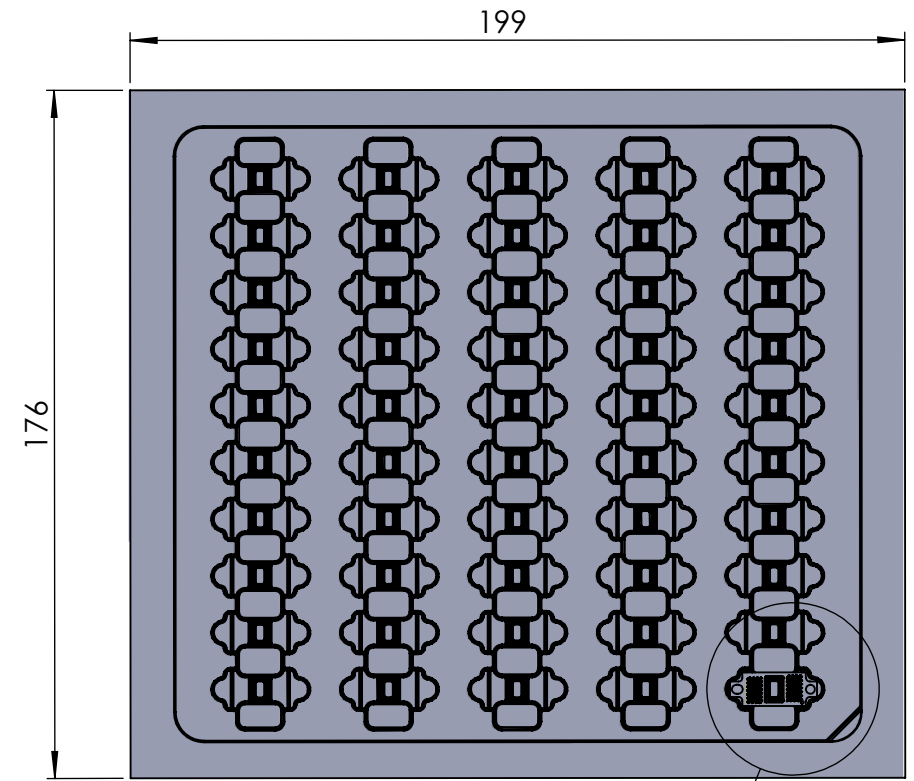
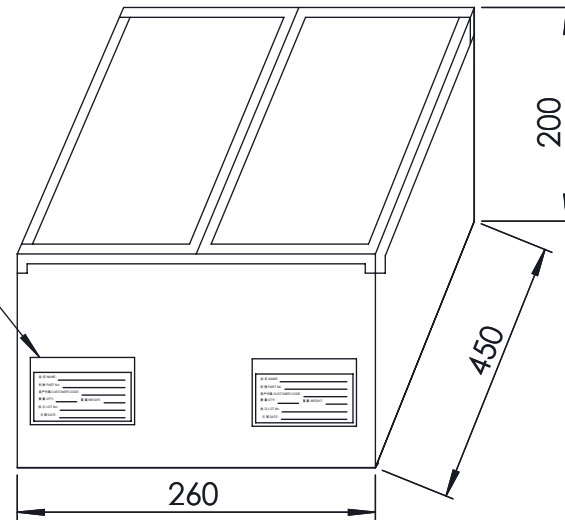

10TRAY/PACKAGE

4 PACKAGE/CARTON

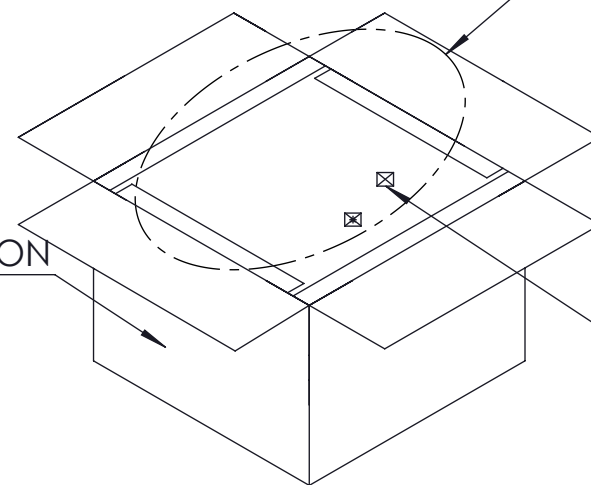

PE PEG

DRIER

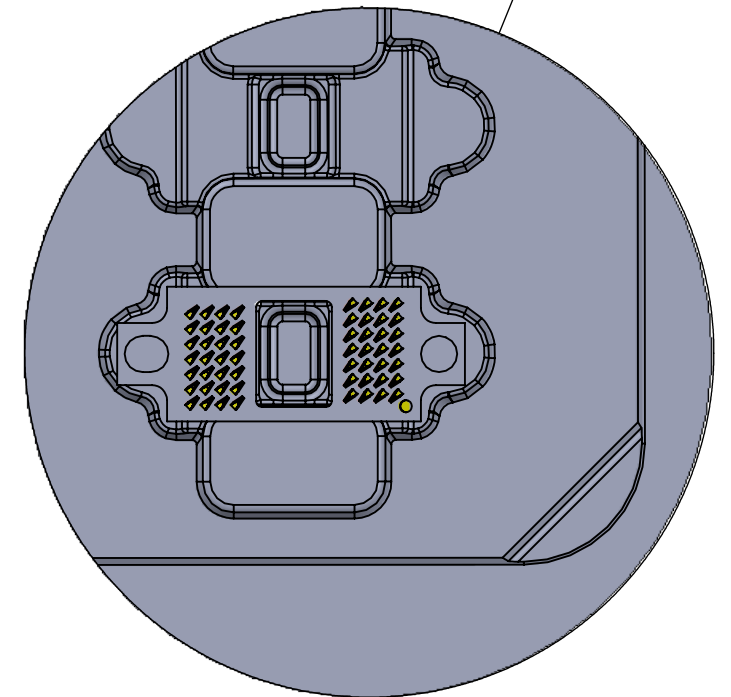

NOTE(UNLESS OTHERWISH SPECIFIED):
1.COMPONENT LOAD PER TRAY : 50PCS
40 TRAY/CARTON: 450mm X 260mm X 200mm.
TOTAL: 2000PCS/CARTON
2.MATERIAL:TRANSPARENT POLYSTYRENE(PS).

neconix
Unimicron

DIMENSIONS ARE IN
MM [INCH]
.X ± 0.15
.XX ± 0.10
.XXX ± 0.05
ANGLE: NO DEC ± 1°
.X ± 0.5°
.XX ± 0.25°



MATERIAL:	
FINISH: --	
DRAWN BY: Jianyu	08/24/2021
CHECKED BY: Gary Hsieh	08/24/2021
ENGR APPR: Gary Hsieh	08/24/2021
MFG APPR:	
QA APPR:	

TITLE: Interposer , LGA/LGA 56 POS Low-Height	
SIZE B+	REV 1
DWG NUMBER: BDX0056DMMSXAU01	
SCALE: 2.5:1	SHEET 3 OF 3