

- PROPRIETARY INFORMATION -
NO USE OR REPRODUCTION MAY BE MADE OF
THIS DOCUMENT WITHOUT EXPRESS WRITTEN
PERMISSION OF NEOCONIX.

REVISIONS				
REV	ECN	DESCRIPTION	DATE	DESIGN BY:
1	0000	INITIAL RELEASE	09-12-2023	TAN

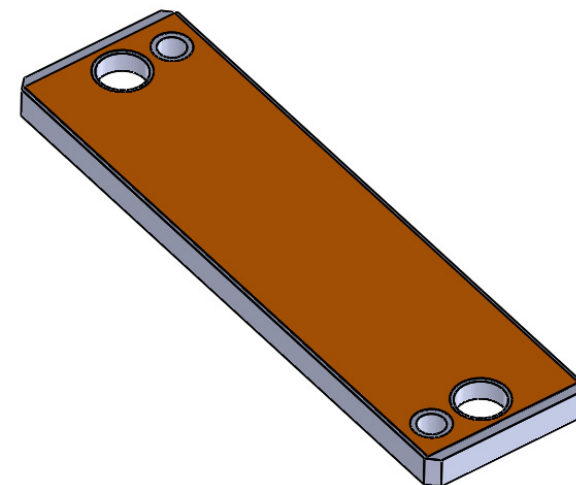
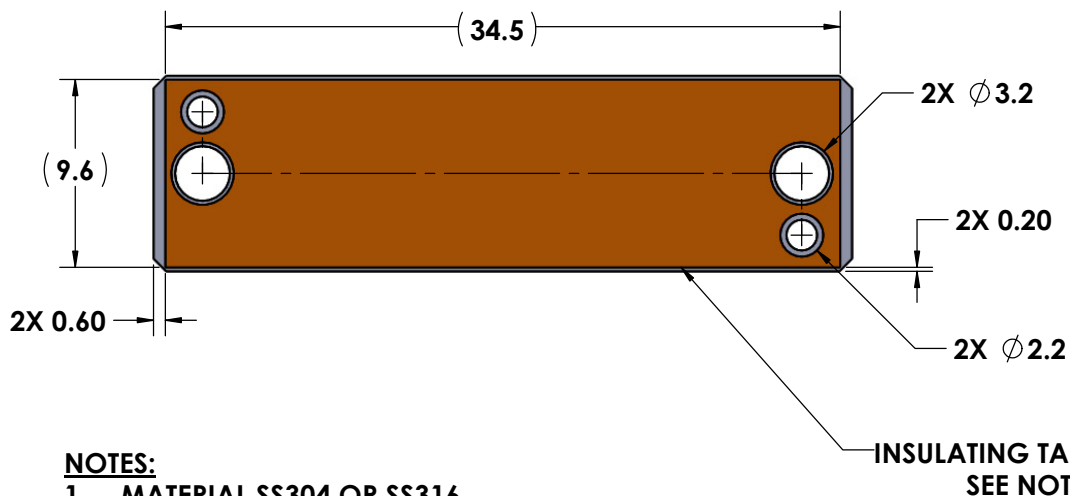
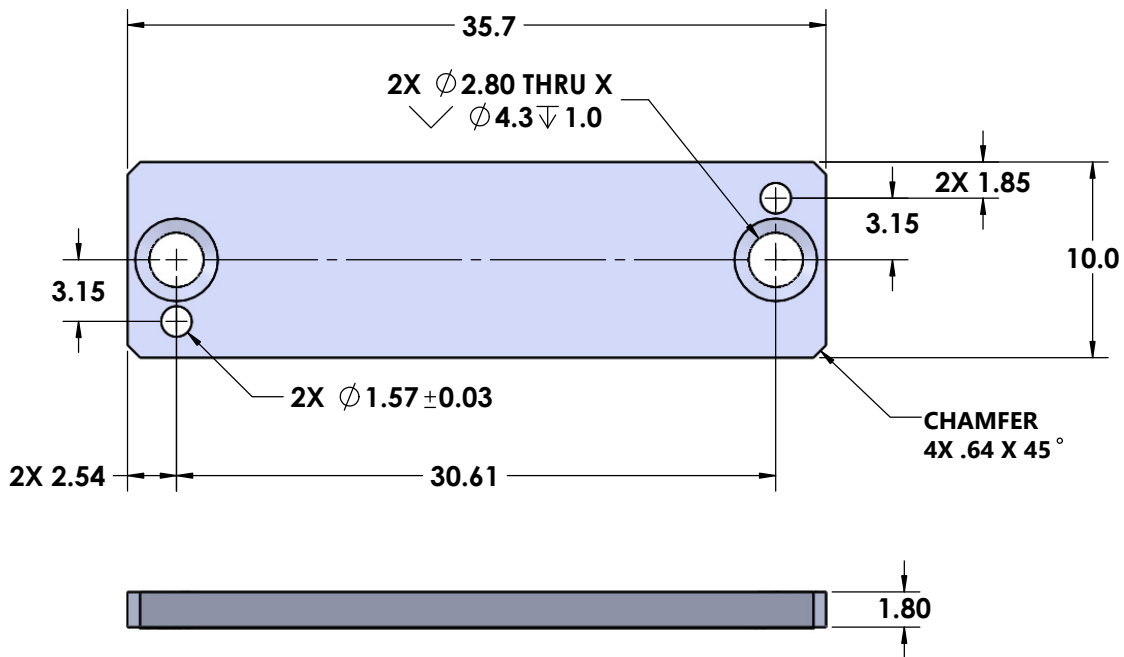

NOTES:

1. MATERIAL SS304 OR SS316
2. COMPLIANT WITH RoHS DIRECTIVE 2011/65/EU.
3. DEBURR ALL EDGES.
4. INSULATING TAPE TESA8853 OR EQUIVALENT.

<p>4020 MOORPARK AVENUE #108 SAN JOSE, CA 95117 USA TEL: 408-530-9393 FAX: 408-530-9383</p>	DIMENSIONS ARE IN MM		MATERIAL: SEE NOTES		TITLE: SPH3 UPPER BACKER + MED FF	
	.X ±0.13	FINISH:	DRAWN BY: TAN NGUYEN		DATE: 09-12-2023	
	.XXX ±0.08	ANGLE: NO DEC ±2 DEGREE	CHECKED BY:		SIZE: B+	
	.XXX ±0.025		ENGR APPR:		DWG NUMBER: B01-000844	
		MFG APPR:		REV: 1		
		QA APPR:		SCALE: 4:1		
THIRD ANGLE			SHEET 1 OF 1			