

REVISIONS				
REV	ECN #	DESCRIPTION	DATE	DRAWN BY:
1	0000	IN STOCK	11/12/2020	TAN

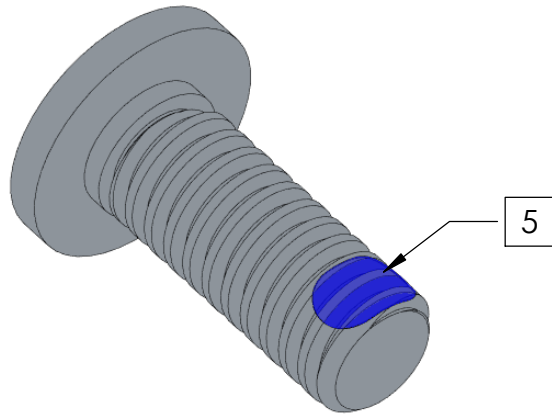
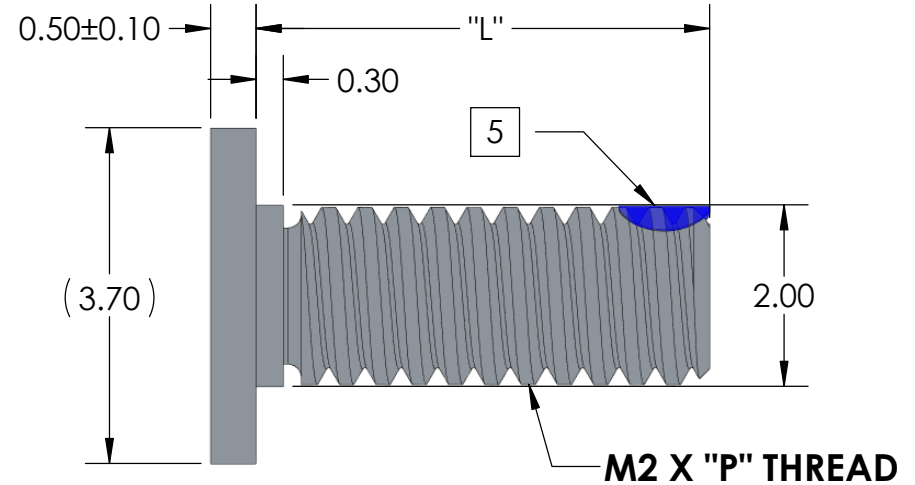
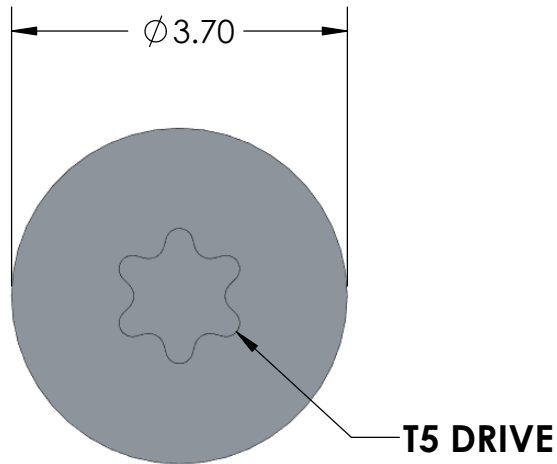

TABLE-1

P/N	"P"	"L"
B01-000799	0.25mm	2mm
B01-000800	0.40mm	3mm
B01-000801	0.40mm	4mm
B01-000802	0.40mm	5mm

NOTES (UNLESS OTHERWISE SPECIFIED):

1. INTERPRET DRAWING PER ASME Y14.5-94.
2. COMPLIANT WITH RoHS DIRECTIVE 2011/65/EU.
3. **MATERIAL:** AISI 1018.
4. **FINISH:** BRIGHT NICKEL PER ASTM B689-97, TYPE 2, CLASS S.
5. **THREADLOCK:** NYLOK-BLUE, FIRST 2-3 WHOLE THREADS, 75° - 150° COVERAGE.
6. SCREW FIT TOLERANCE DOES NOT INCLUDE THREADLOCK.
7. PART TO BE FREE OF BURRS AND SHARP EDGES.

DIMENSIONS ARE IN mm TOLERANCES (unless otherwise specified): ANGULAR: ± 2 degree LINEAR: .X ± 0.13 .XX ± 0.08 .XXX ± 0.025		NAME TAN NGUYEN	DATE 08/11/2020	<p>4020 MOORPARK AVE., SUITE 108. SAN JOSE, CA 95117 TEL: 408-530-9393 FAX: 408-530-9383</p>
MATERIAL AISI1018		DRAWN	CHECKED	
FINISH		APPROVAL	Release level	
COMMENTS: DO NOT SCALE DRAWING		RELEASED		
projection		Title: M2 SCREW TABULATION DRAWING		DWG. NO. B01-000803
		SIZE A	SCALE:5:1	
		WEIGHT:		SHEET 1 OF 1