

REVISIONS				
REV	ECN #	DESCRIPTION	DATE	DRAWN BY:
1	0000	IN STOCK	11/12/2020	TAN

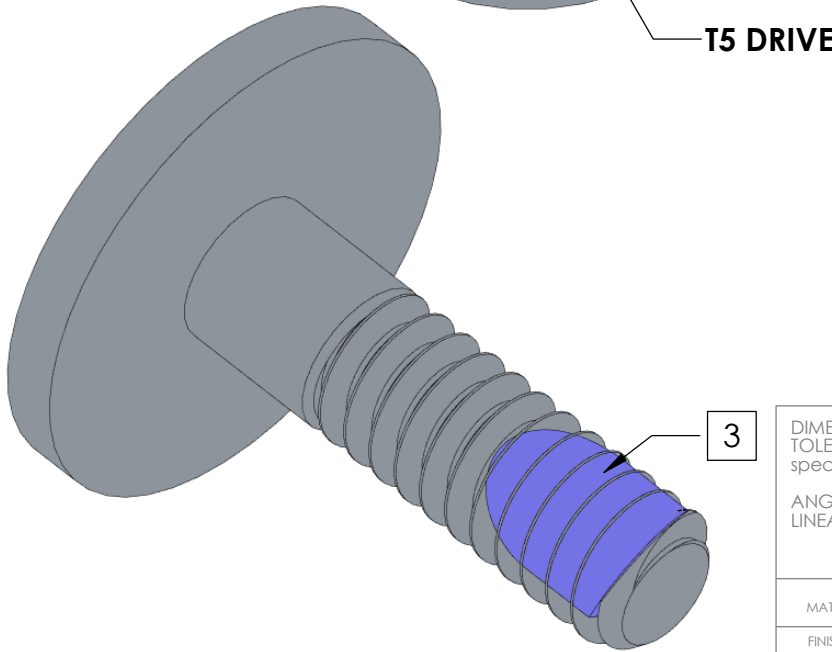
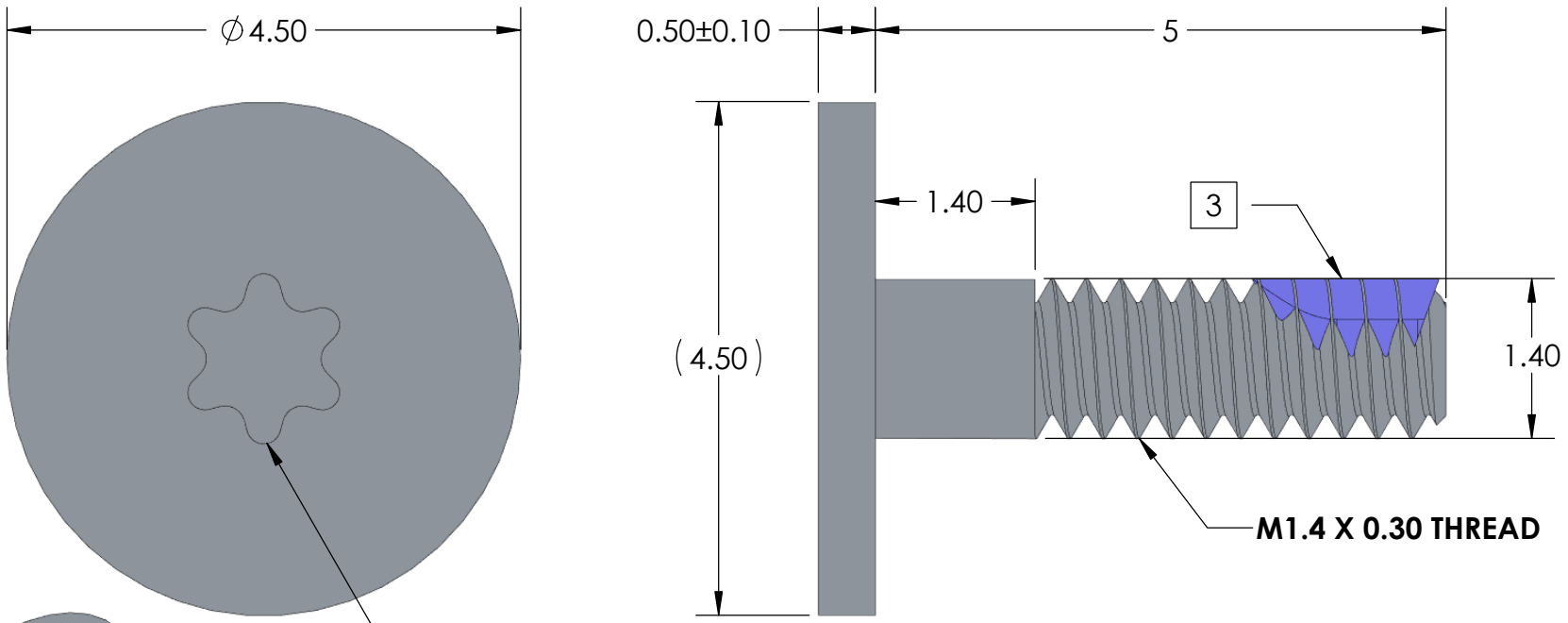

- NOTES:
1. MATERIAL: AISI 1018.
 2. FINISH: BRIGHT NICKEL PER ASTM B689-97, TYPE 2, CLASS S.
 3. THREADLOCK: NYLOK-BLUE, FIRST 2-3 WHOLE THREADS, 75° - 150° COVERAGE.
 4. SCREW FIT TOLERANCE DOES NOT INCLUDE THREADLOCK.
 5. PART TO BE FREE OF BURRS AND SHARP EDGES.

DIMENSIONS ARE IN mm TOLERANCES (unless otherwise specified): ANGULAR: ± 2 degree LINEAR: .X ±0.13 .XX ±0.08 .XXX ±0.025	NAME	DATE	4020 MOORPARK AVE., SUITE 108. SAN JOSE, CA 95117 TEL: 408-530-9393 FAX: 408-530-9383			
	DRAWN	Tan Nguyen			08/21/2020	
	CHECKED					
	Appr		Title: SCREW, M1.4 X .30PITCH x 5mm-LG			
	Release level				RELEASED	
MATERIAL	AISI1018	COMMENTS:	projection	SIZE	DWG. NO.	REV
FINISH		DO NOT SCALE DRAWING		A	B01-000798	1
			SCALE:5:1	WEIGHT:	SHEET 1 OF 1	