

REVISIONS				
REV	ECN #	DESCRIPTION	DATE	DRAWN BY:
1	0000	IN STOCK	11/12/2020	TAN

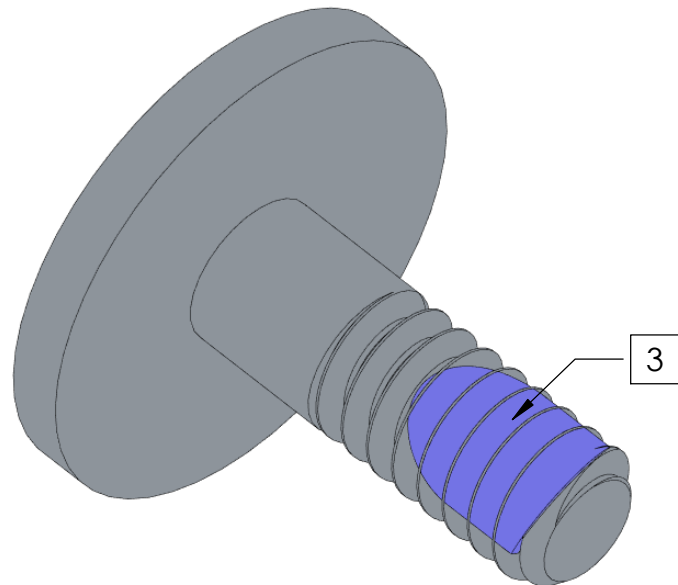
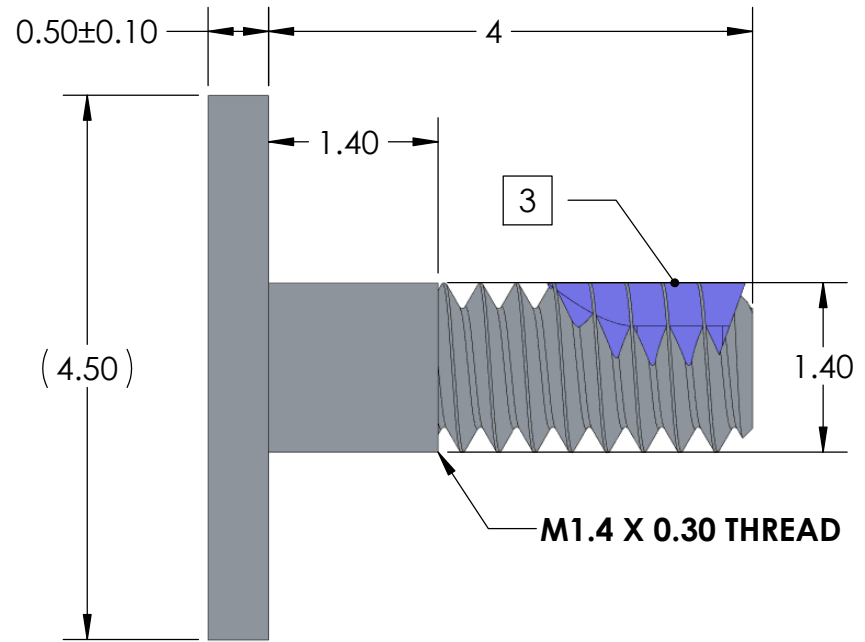
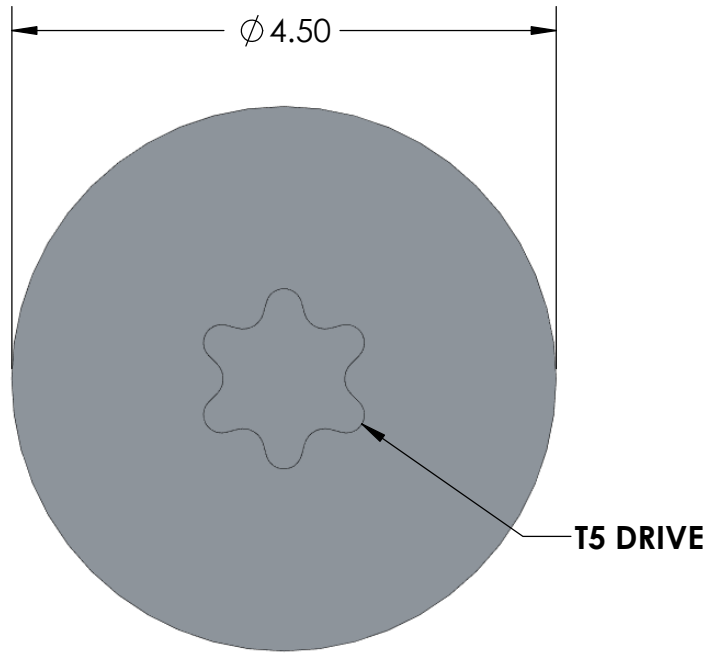

NOTES:

1. MATERIAL: AISI 1018.
2. FINISH: BRIGHT NICKEL PER ASTM B689-97, TYPE 2, CLASS S.
3. THREADLOCK: NYLOK-BLUE, FIRST 2-3 WHOLE THREADS, 75° - 150° COVERAGE.
4. SCREW FIT TOLERANCE DOES NOT INCLUDE THREADLOCK.
5. PART TO BE FREE OF BURRS AND SHARP EDGES.

DIMENSIONS ARE IN mm TOLERANCES (unless otherwise specified):		NAME	DATE	 4020 MOORPARK AVE., SUITE 108. SAN JOSE, CA 95117 TEL: 408-530-9393 FAX: 408-530-9383
ANGULAR: ± 2 degree		DRAWN	Tan Nguyen	
LINEAR: .X ± 0.13 .XX ± 0.08 .XXX ± 0.025		CHECKED		
MATERIAL AISI1018		Appr		Title: SCREW, M1.4 X .30PITCH x 4mm-LG
FINISH		Release level	RELEASED	
DO NOT SCALE DRAWING		projection		DWG. NO. B01-000797 SCALE: 5:1 WEIGHT: SHEET 1 OF 1