

REVISIONS				
REV	ECN #	DESCRIPTION	DATE	DRAWN BY:
1	0000	PRE-RELEASE	10/29/2015	TAN
2	0000	CHANGE TO T5 TORX HEAD DRIVER	11/05/2015	TAN
3	1277	CHANGE SCREW HEAD TO #0-PHILLIPS DRIVE	11/12/2020	TAN

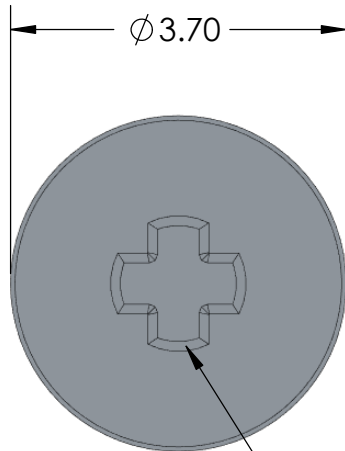

#0-PHILLIPS DRIVE

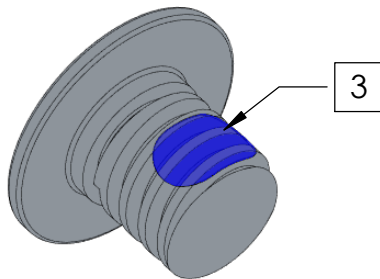
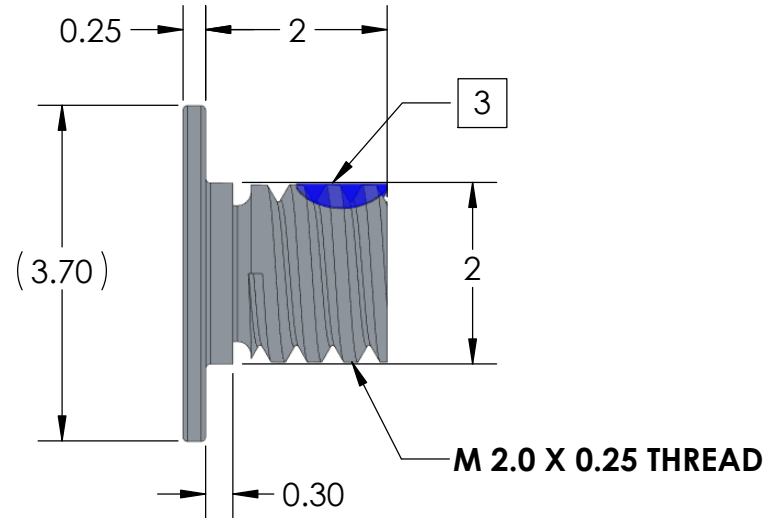

NOTES:

1. MATERIAL: AISI 1018.
2. FINISH: BRIGHT NICKEL PER ASTM B689-97, TYPE 2, CLASS S.
3. THREADLOCK: NYLOK-BLUE, FIRST 2-3 WHOLE THREADS, 75°-150° COVERAGE.
4. SCREW FIT TOLERANCE DOES NOT INCLUDE THREADLOCK.
5. PART TO BE FREE OF BURRS AND SHARP EDGES.

DIMENSIONS ARE IN mm TOLERANCES (unless otherwise specified):		NAME	DATE	 4020 MOORPARK AVE., SUITE 108. SAN JOSE, CA 95117 TEL: 408-530-9393 FAX: 408-530-9383	
ANGULAR: ± 2 degree LINEAR: .X ±0.13 .XX ±0.08 .XXX ±0.025		DRAWN	Tan Nguyen		10/29/2015
		CHECKED			
		Appr			
		Release level	RELEASED		
MATERIAL	AISI1018	COMMENTS:	Projection	Title: SCREW, M2.0 X .40PITCH X 2mm-LG	
FINISH		DO NOT SCALE DRAWING			
		SIZE	A	DWG. NO.	
				B01-000662	
		SCALE:5:1	WEIGHT:	SHEET 1 OF 1	
				REV 3	