

REVISIONS				
REV	ECN #	DESCRIPTION	DATE	DRAWN BY:
1	0000	PRE-RELEASE	10/29/2015	TAN
2	0000	CHANGE TO T5 TORX HEAD DRIVER	11/05/2015	TAN
3	1277	CHANGE SCREW HEAD TO #0-PHILLIPS DRIVE	11/12/2020	TAN

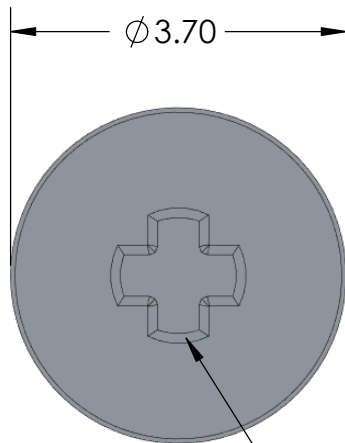

#0-PHILLIPS DRIVE

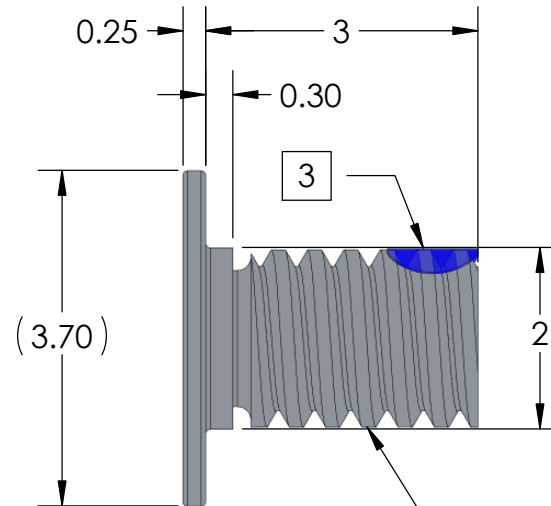

M 2.0 X 0.40 THREAD

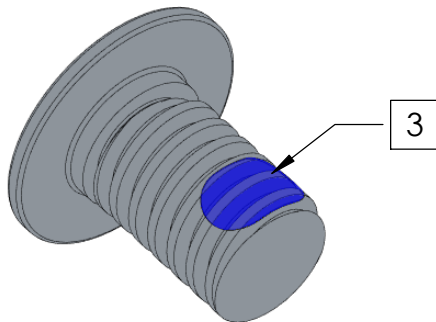

NOTES:

1. MATERIAL: AISI 1018.
2. FINISH: BRIGHT NICKEL PER ASTM B689-97, TYPE 2, CLASS S.
3. THREADLOCK: NYLOK-BLUE, FIRST 2-3 WHOLE THREADS, 75°-150° COVERAGE.
4. SCREW FIT TOLERANCE DOES NOT INCLUDE THREADLOCK.
5. PART TO BE FREE OF BURRS AND SHARP EDGES.

DIMENSIONS ARE IN mm TOLERANCES (unless otherwise specified):		NAME	DATE	 4020 MOORPARK AVE., SUITE 108. SAN JOSE, CA 95117 TEL: 408-530-9393 FAX: 408-530-9383	
ANGULAR: ± 2 degree LINEAR: .X ±0.13 .XX ±0.08 .XXX ±0.025		DRAWN	Tan Nguyen		10/29/2015
MATERIAL AISI1018		CHECKED			
FINISH		Appr			
		Release level	<b>RELEASED</b>		
		COMMENTS:	projection	Title: <b>SCREW, M2.0 X .40PITCH X 3mm-LG</b>	
		DO NOT SCALE DRAWING		DWG. NO. <b>B01-000661</b>	
			SIZE <b>A</b>	REV <b>3</b>	
			SCALE:5:1	WEIGHT:	
				SHEET 1 OF 1	