

REVISIONS				
REV	ECN #	DESCRIPTION	DATE	DRAWN BY:
1	0000	PRODUCT RELEASED	08/12/2014	TAN
2	1277	CHANGE SCREW HEAD TO #0-PHILLIPS DRIVE	11/12/2020	TAN

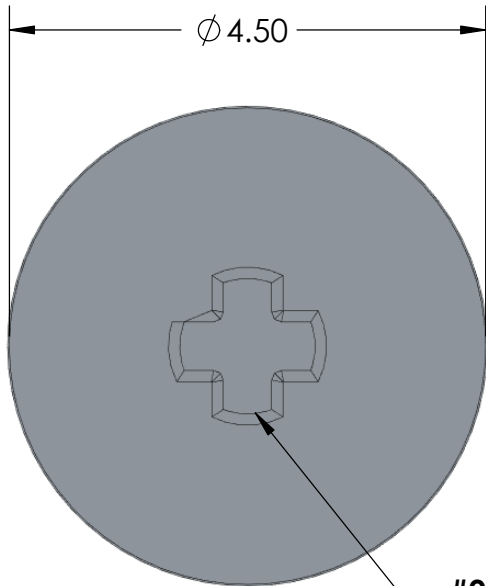

#0-PHILLIPS DRIVE

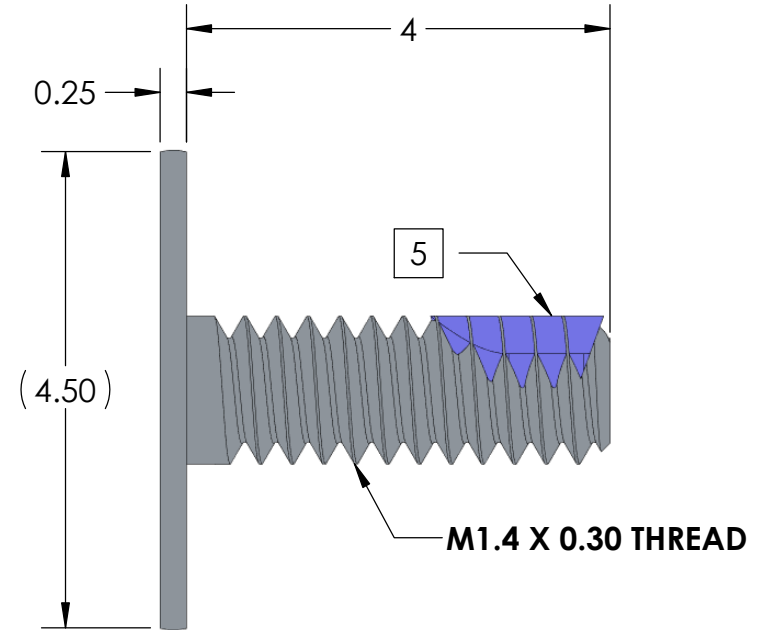

M1.4 X 0.30 THREAD

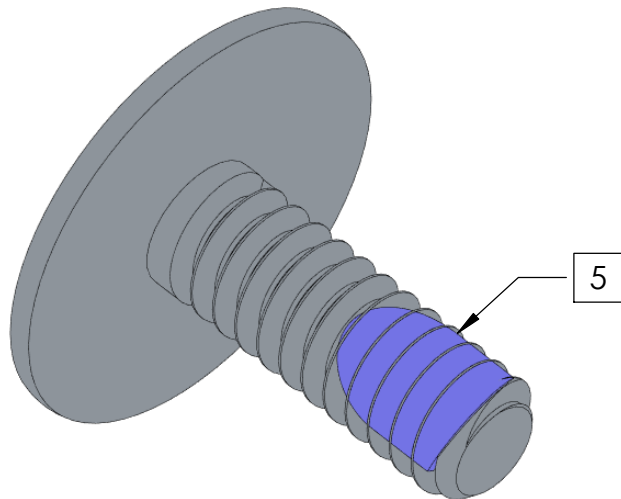

NOTES (UNLESS OTHERWISE SPECIFIED):

1. INTERPRET DRAWING PER ASME Y14.5-94.
2. COMPLIANT WITH RoHS DIRECTIVE 2011/65/EU.
3. **MATERIAL:** AISI 1018.
4. **FINISH:** BRIGHT NICKEL PER ASTM B689-97, TYPE 2, CLASS S.
5. **THREADLOCK:** NYLOK-BLUE, FIRST 2-3 WHOLE THREADS, 75°-150° COVERAGE.
6. SCREW FIT TOLERANCE DOES NOT INCLUDE THREADLOCK.
7. PART TO BE FREE OF BURRS AND SHARP EDGES.

DIMENSIONS ARE IN mm TOLERANCES (unless otherwise specified): ANGULAR: ± 2 degree LINEAR: .X ± 0.13 .XX ± 0.08 .XXX ± 0.025		NAME Tan Nguyen	DATE 08/12/2014	 4020 MOORPARK AVE., SUITE 108. SAN JOSE, CA 95117 TEL: 408-530-9393 FAX: 408-530-9383	Title: SCREW, M1.4 X .30PITCH x 4mm-LG	
MATERIAL AISI1018	FINISH	DRAWN	CHECKED		Appr	Release level
COMMENTS: DO NOT SCALE DRAWING		Projection 		SIZE A	DWG. NO. B01-000657	REV 2
		SCALE:5:1		WEIGHT:		SHEET 1 OF 1