

- PROPRIETARY INFORMATION -
NO USE OR REPRODUCTION MAY BE MADE OF
THIS DOCUMENT WITHOUT EXPRESS WRITTEN
PERMISSION OF NEOCONIX.

REVISIONS				
ZONE	REV.	DESCRIPTION	DATE	DRAWN BY:
	1	INITIAL RELEASE	10-29-2015	TAN

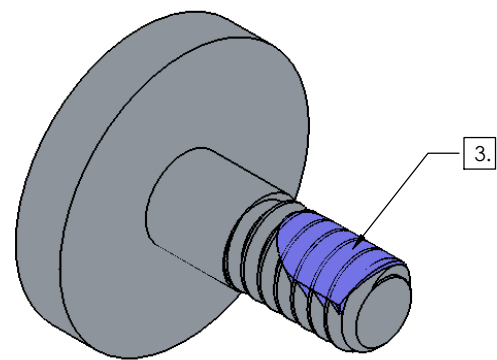
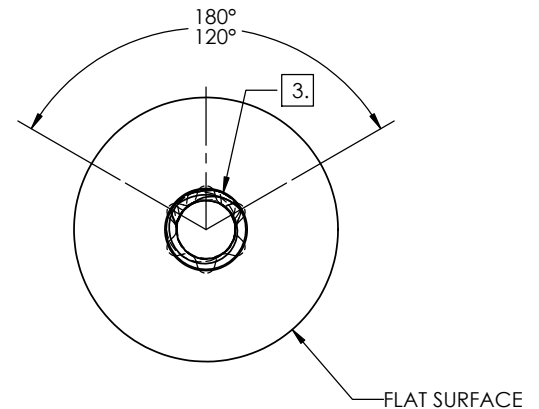
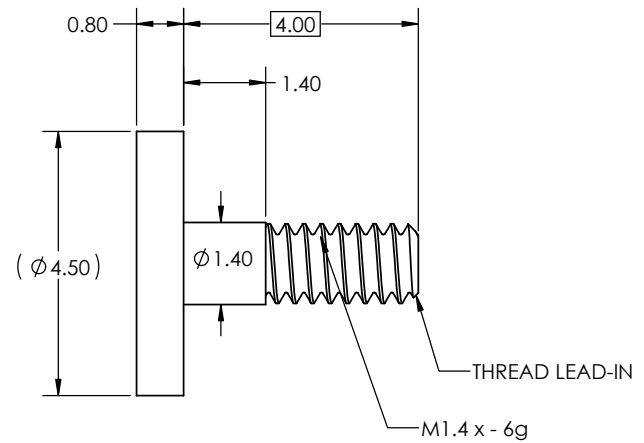
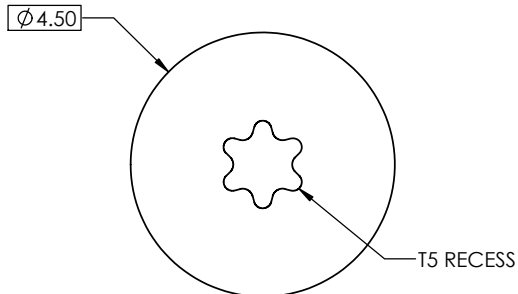

- NOTES:
1. MATERIAL: AISI 1018
 2. FINISH: BRIGHT NICKEL PER ASTM B689-97, TYPE 2, CLASS 5
 3. THREADLOCK: NYLOK-BLUE, FIRST 4-6 WHOLE THREADS, 120°-180° COVERAGE.
 4. SCREW FIT TOLERANCE DOES NOT INCLUDE THREADLOCK.
 5. PART TO BE FREE OF BURRS AND SHARP EDGES.

<p>2355-C PARAGON DRIVE. SAN JOSE, CA 95131 TEL: 408-530-9393 FAX: 408-530-9383</p>	<p>DIMENSIONS ARE IN MM [INCH] .X ± 0.20 [.008] .XX ± 0.10 [.004] .XXX ± 0.025 [.001] ANGLE: NO DEC ± 1.5° .X ± 0.5° .XX ± 0.25°</p>	<p>MATERIAL: SEE NOTES FINISH: SEE NOTES DRAWN BY: TAN NGUYEN 10-29-2015 CHECKED BY: ENGR APPR: MFG APPR: QA APPR:</p>	<p>TITLE: Screw, M1.4 x 0.30mm Thread Pitch, 4mm Length.</p>	
	<p>SIZE B+</p>	<p>DWG NUMBER: B01-000657</p>	<p>REV 1</p>	<p>SCALE: 12:1 SHEET 1 OF 1</p>
	<p>THIRD ANGLE</p>			