

REVISIONS				
REV.	ECN #	DESCRIPTION	DATE	DRAWN BY:
A	1190	RELEASE TO PRODUCTION	07/31/2017	TAN

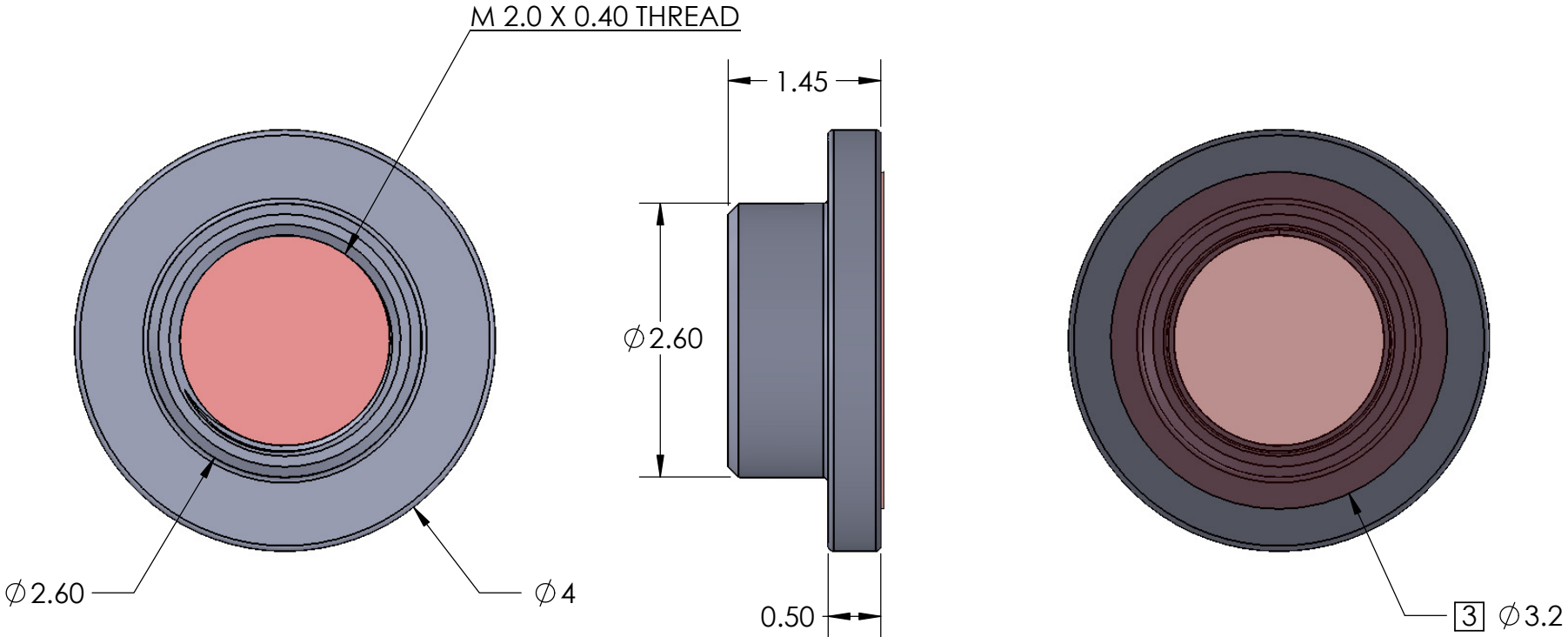

NOTES:

- MATERIAL: PHOSPHOR BRONZE, UNS C54400 H04 TEMPER (UTS 450MPa MIN) OR EQUIVALENT.
- FINISH: 120u" MIN BRIGHT TIN OVER 40u" MIN NICKEL UNDER PLATE.
- 3 HI-TEMP POLYIMIDE TAPE, 260 °C [500 °F] MINIMUM, TOTAL THICKNESS .025-.076 MM [.001-.003 IN] ADHESION TO STEEL 27 N/100 MM [25 OZ/IN] MINIMUM, PER ASTM D3330 OR EQUIV.
- PART TO BE FREE OF BURRS AND SHARP EDGES.

DIMENSIONS ARE IN mm TOLERANCES (unless otherwise specified): ANGULAR: ± 2 degree LINEAR: .X ± 0.15 .XX ± 0.10 .XXX ± 0.05	
MATERIAL	
FINISH	

	NAME	DATE
DRAWN	TAN NGUYEN	07/31/2017
CHECKED		
Appr		
Release level	PRODUCTION	
COMMENTS:	DO NOT SCALE DRAWING	



Title: **SMT NUT, M2.0 X 0.40 THREAD PITCH [FOR >1.0mm THK PCB]**

SIZE A	DWG. NO. B01-000654	REV. A
SCALE:5:1	WEIGHT:	SHEET 1 OF 1

