

- PROPRIETARY INFORMATION -
NO USE OR REPRODUCTION MAY BE MADE OF
THIS DOCUMENT WITHOUT EXPRESS WRITTEN
PERMISSION OF NEOCONIX.

REVISIONS

REV	ECN #	DESCRIPTION	DATE	APPROVED
1	0000	INITIAL	09-09-2013	TAN
2	1186	SEE ECN	05-23-2017	TAN

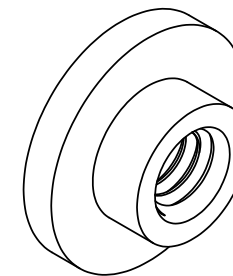
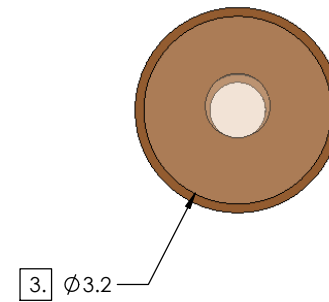
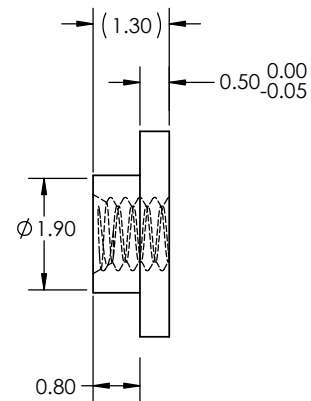
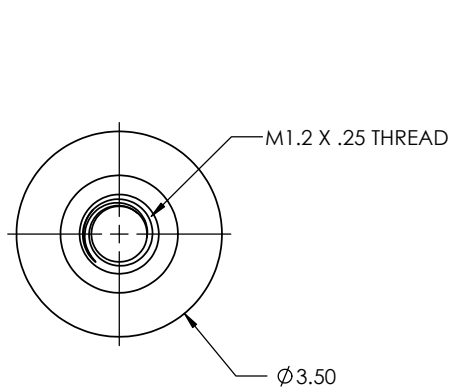

NOTES:

- MATERIAL: PHOSPHOR BRONZE, UNS C54400 H04 TEMPER (UTS 450MPa MIN) OR EQUIVALENT.
- FINISH: 120u" MIN BRIGHT TIN OVER 40u" MIN NICKEL UNDER PLATE.
- 3** HI-TEMP POLYIMIDE TAPE, 260 °C [500 °F] MINIMUM, TOTAL THICKNESS .025-.076 MM [.001-.003 IN], ADHESION TO STEEL 27 N/100 MM [25 OZ/IN] MINIMUM, PER ASTM D3330 OR EQUIVALENT.
- PART TO BE FREE OF BURRS AND SHARP EDGES.

<p>4020 Moorpark Ave, Suite 108, San Jose, CA, 95117</p> <p>TEL: 408-530-9393 FAX: 408-530-9372</p>	<p>DIMENSIONS ARE IN MM [INCH]</p> <p>.X ± 0.20 [.008]</p> <p>.XX ± 0.10 [.004]</p> <p>.XXX ± 0.025 [.001]</p> <p>ANGLE: NO DEC ± 1.5°</p> <p>.X ± 0.5°</p> <p>.XX ± 0.25°</p>	<p>MATERIAL: SEE NOTES</p> <p>FINISH: SEE NOTES</p> <p>DRAWN BY: TAN NGUYEN 09-09-2013</p> <p>CHECKED BY: W MAYNARD 09-09-2013</p> <p>ENGR APPR:</p> <p>MFG APPR:</p> <p>QA APPR:</p>	<p>TITLE: NUT, M1.2 X .80mm LG</p> <p>DWG NUMBER: B01-000588</p> <p>SCALE: 12:1</p>	<p>REV 2</p> <p>SHEET 1 OF 1</p>
	<p>THIRD ANGLE</p>	<p>SIZE: B+</p>	<p>DATE: 09-09-2013</p>	<p>REV: 2</p>
	<p>DATE: 09-09-2013</p>	<p>DATE: 09-09-2013</p>	<p>DATE: 09-09-2013</p>	<p>DATE: 09-09-2013</p>
	<p>DATE: 09-09-2013</p>	<p>DATE: 09-09-2013</p>	<p>DATE: 09-09-2013</p>	<p>DATE: 09-09-2013</p>