

Product Specification: SPH2 Family of Standard Interposers

FEATURES

- High Performance PCBeam™ Connector Technology
- Product options at 1.27mm, 1.0mm, 0.8mm, and 0.65mm pitch
- Increased pin count per form factor vs. SPH1
- 3 physical sizes available
- Standard interposer thickness of 0.8mm
 - All assembly hardware included (optional)
- RoHS 2011/65/EU compliant

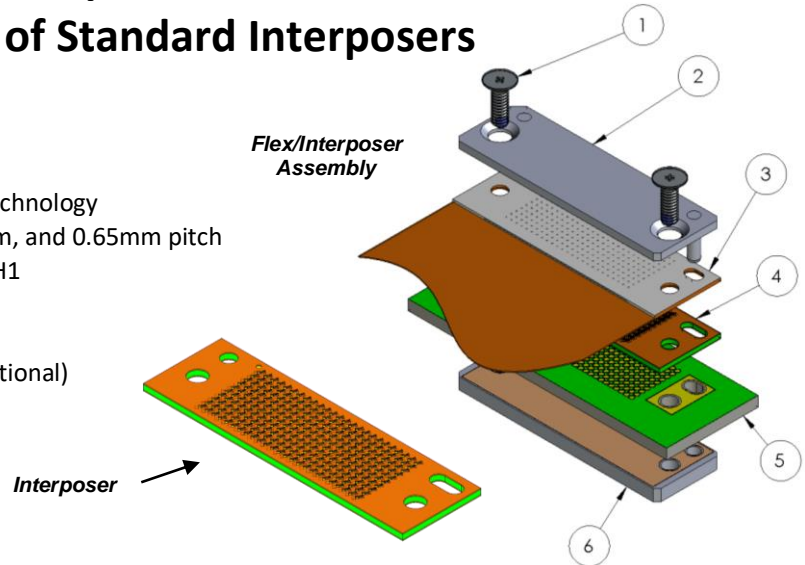

OVERVIEW

The Neoconix SPH2 family of PCBeam™ interposer standard products has been developed for high performance board-to-board and flex-to-board applications. While similar to the 5 row SPH1 product family, the SPH2 product family increases the pin count on each interposer size. There are 4 pitch options ranging from 1.27mm pitch to 0.65mm pitch. Custom variants are also possible. Compatible hardware is available for simple and reliable assembly into the host system. Optionally, Neoconix can simplify the implementation by also designing and providing the associated FPC.

Standard configurations are as shown below:

Item	INTERPOSER PART NUMBER	HARDWARE SIZE	PITCH (mm)	POSITIONS	ROWS	COLS	LENGTH (mm)	WIDTH	MATED HEIGHT
1	SPH2-SF102A	Small	1.27	102	6	17	31.8	9.6mm	0.8mm
2	SPH2-MF120A	Medium		120	6	20	35.7		
3	SPH2-LF150A	Large		150	6	25	41.9		
4	SPH2-SD160A	Small	1.00	160	8	20	31.8		
5	SPH2-MD200A	Medium		200	8	25	35.7		
6	SPH2-LD240A	Large		240	8	22	41.9		
7	SPH2-SC250A	Small	0.80	250	10	25	31.8		
8	SPH2-MC300A	Medium		300	10	30	35.7		
9	SPH2-LC400A	Large		400	10	40	41.9		
10	SPH2-SC384A	Small	0.65	384	12	32	31.8		
11	SPH2-MC456A	Medium		456	12	38	35.7		
12	SPH2-LC576A	Large		576	12	48	41.9		

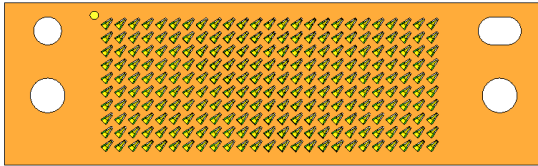

250 position, 0.8mm Pitch Interposer

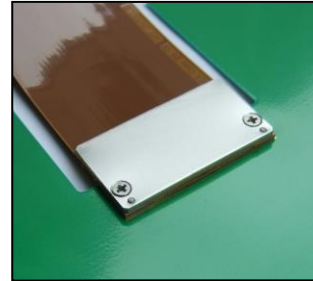

PCBeam™ TECHNOLOGY BACKGROUND:

Neoconix interposers are built using innovative PCBeam™ technology. Based on the principles of printed circuit board processing, this lithography & etch based manufacturing method provides unparalleled design flexibility, precision, and performance. Prototype costs and lead times are greatly reduced since no molds are required, and high volume cost-effectiveness is gained through large scale batch processing.

Neoconix' PCBeam interposers and product extensions offer many features, including the following:

- Continuous, all-metal spring contacts
- Large spring deflection up to 0.50mm to tolerate flatness variations on mating boards
- High current carrying capacity >1.5A
- Excellent signal integrity to 112 Gbps+
- Integrated contact elements – no loose pieces
- Low profile to 0.28mm
- A continuum of available thickness options
- High density capabilities at 0.65mm array pitch and 0.5mm row pitch
- Excellent true position capabilities
- Optional SMT configuration with solder balls pre-attached on one side of interposer
- High volume manufacturing in Asia-Pacific

While the standard products here are defined with specific configurations, Neoconix' PCBeam technology inherently has tremendous design flexibility. In many cases, fully custom designs can be built with no new tooling required. Flex circuit design and manufacturing is also available to enable fully integrated flex/interposer assemblies.

DOCUMENT NUMBER: AS-000034	REV.D 4/12/2023	SPH2 Family of Standard Interposers	AUTHOR: WT	Page 2 of 15
--------------------------------------	---------------------------	--	----------------------	------------------------

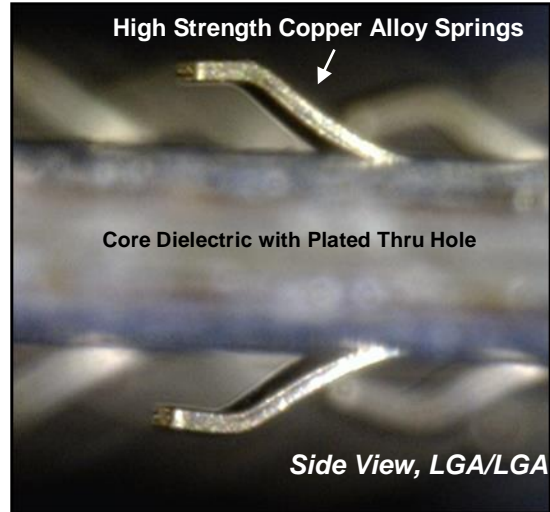
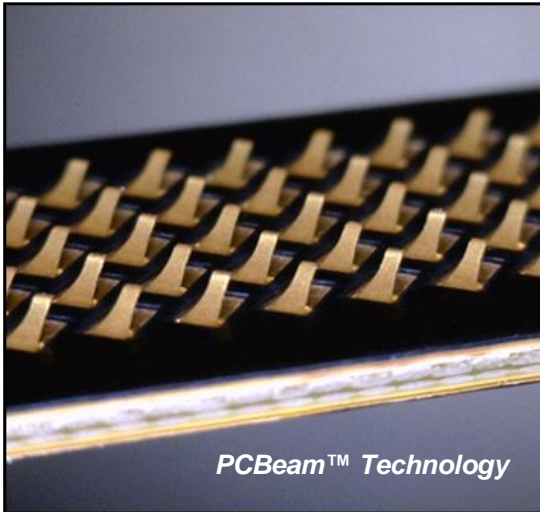

SPH2 INTERPOSER SPECIFICATIONS*
MECHANICAL

Contact Configuration.....	single-beam, LGA/LGA
Contact Pitch.....	1.27mm, 1.0mm, 0.8mm, 0.65mm
Typical Load / Contact (1.27, 1.0, 0.8, 0.65mm pitch).....	55g, 35g, 30g, 25g
Contact Deflection/Side (1.27, 1.0, 0.8, 0.65mm pitch).....	0.25mm, 0.20mm, 0.18mm, 0.18mm
Contact Deflection Both Sides (1.27, 1.0, 0.8mm pitch).....	0.50mm, 0.40mm, 0.36mm, 0.36mm

ELECTRICAL

Current Rating/Pin, Single Pin (1.27, 1.0, 0.8, 0.65mm pitch).....	2.0A, 1.5A, 1.25A, 0.5A per position
Current Rating/Pin, Group of 5 pins** (1.27, 1.0, 0.8, 0.65mm pitch)....	0.9A, 0.7A, 0.6A, 0.3A per position
Average Resistance.....	< 30mΩ per position
Insertion Loss @ 10GHz (20Gbps), 0.8mm thickness.....	< 1dB
Dielectric Withstanding Voltage.....	100 VAC
Insulation Resistance.....	100 MΩ

ENVIRONMENTAL

Operating Temperature.....	-40°C to 105°C
Storage Temperature.....	-40°C to 105°C
Humidity.....	500 hrs, 80% RH, 25°C to 85°C
Heat Aging.....	500 hrs, 100°C
Temperature Cycling.....	1,000 cycles, 0°C to 100°C
Thermal Shock.....	10 cycles, -40°C to 60°C
Salt Spray.....	48 hrs
Mechanical Shock.....	50 g, 3 axis
Random Vibration.....	0.02-0.04 g ² /Hz, 3 axis
Insertions.....	100 mating cycles

MATERIALS

Core Dielectric.....	laminate
Contact Elements.....	copper alloy
Contact Plating.....	15 μin hard Au over Ni
Surface Insulator.....	polyimide

* Specifications are subject to change without notice.

** Current rating assumes group of 5 has separation of at least 3 pitch units from additional power pins

DOCUMENT NUMBER: AS-000034	REV.D 4/12/2023	SPH2 Family of Standard Interposers	AUTHOR: WT	Page 4 of 15
--------------------------------------	---------------------------	--	----------------------	------------------------

DIMENSIONAL INFORMATION - INTERPOSERS

(Example = SPH2-SC250A, 250pos)

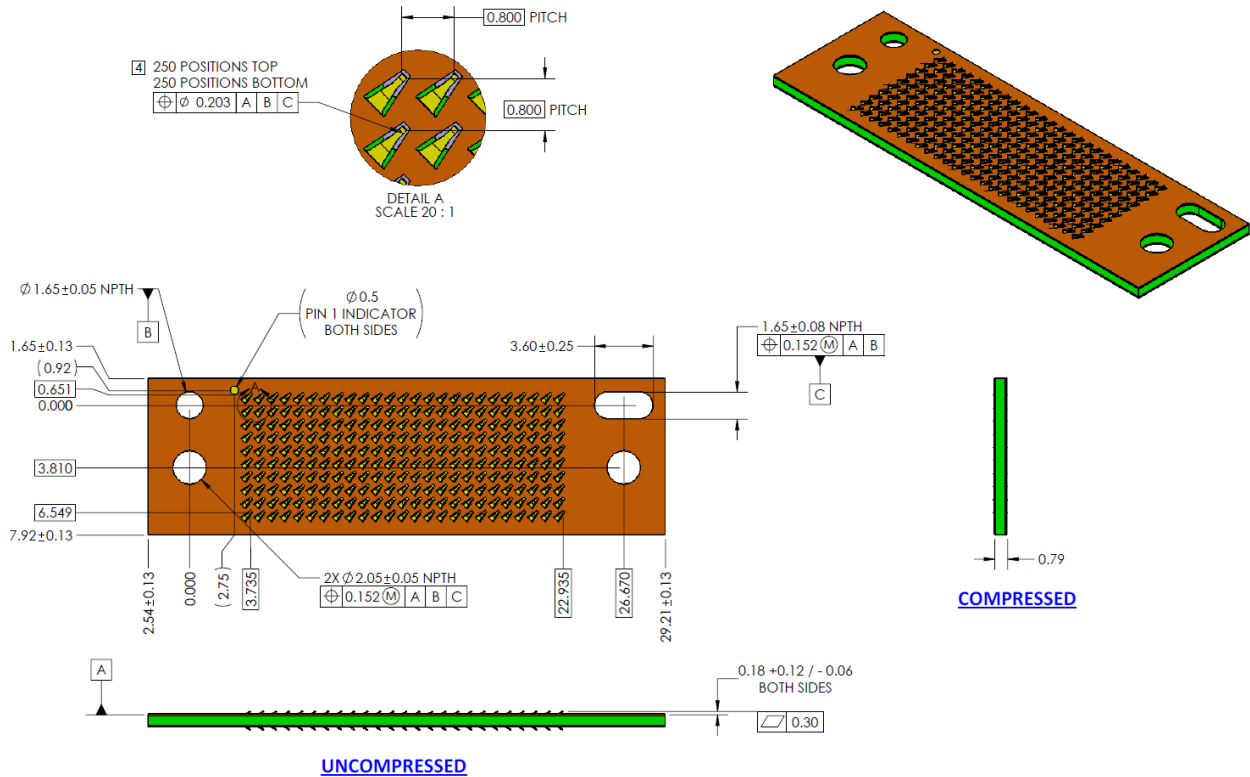

Note: This example is for reference only. Please refer to the product drawing for the specific part number of interest.

DOCUMENT NUMBER: AS-000034	REV.D 4/12/2023	SPH2 Family of Standard Interposers	AUTHOR: WT	Page 5 of 15
--------------------------------------	---------------------------	--	----------------------	------------------------

RECOMMENDED FPC DESIGN

(Example = SPH2-SC250A, 250pos)

The recommended pad geometry is described below for reference. The center contact area for SPH2-SC250A is 0.60mm in diameter. The via is located under the “base” of the corresponding contact spring.

Recommended plating finishes are ENIG, ENEPIG, or electrolytic hard gold.

The specific FPC layout recommendation is included in the drawing package for each SPH2 part number.

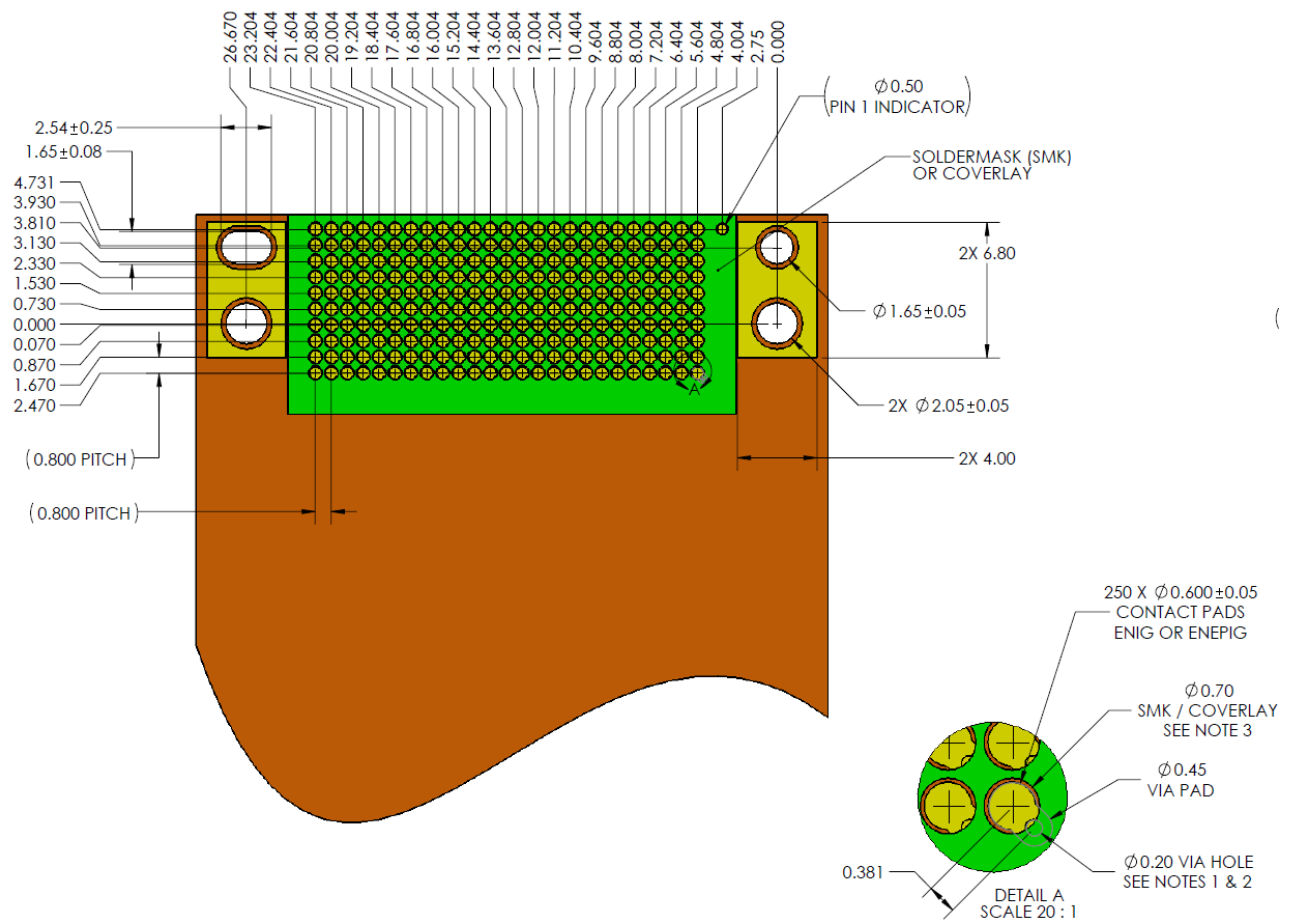

DOCUMENT NUMBER: AS-000034	REV.D 4/12/2023	SPH2 Family of Standard Interposers	AUTHOR: WT	Page 6 of 15
--------------------------------------	---------------------------	---	----------------------	------------------------

RECOMMENDED PCB DESIGN

(Example = SPH2-SC250A, 250pos)

The recommended pad geometry for the PCB is analogous to the geometry for the FPC. An example is shown below for reference. Detailed recommendations for each part number are included in each part number's drawing set.

The PCB mating pads must be gold plated with ENIG, ENEPIG, or electrolytic hard gold.

With the FPC or PCB layout, it is possible to deviate from the pad geometry shown, but a Neoconix review is suggested, and a separate tolerance analysis is recommended if the pad size will be smaller than shown below.

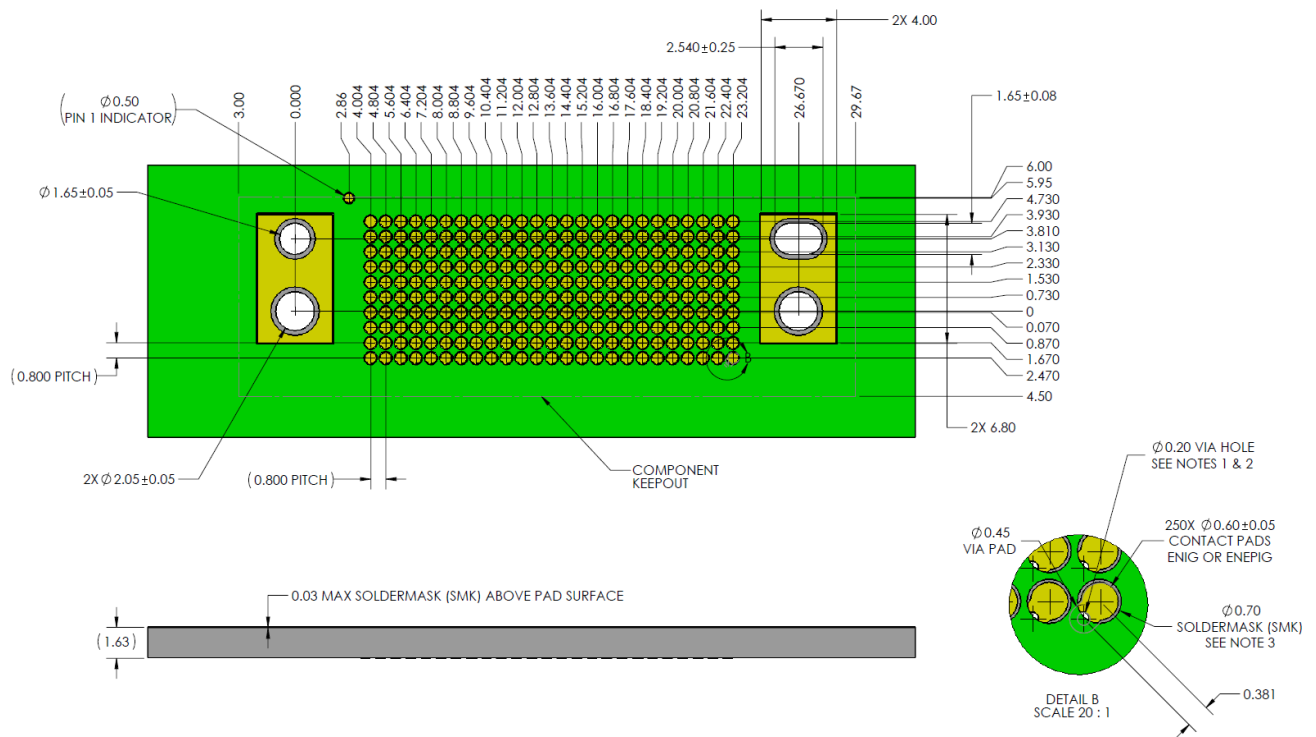

DOCUMENT NUMBER: AS-000034	REV.D 4/12/2023	SPH2 Family of Standard Interposers	AUTHOR: WT	Page 7 of 15
--------------------------------------	---------------------------	---	----------------------	------------------------

COMPRESSION HARDWARE (Optional)

Neoconix has designed hardware compatible with the SPH2 interposer product family. The hardware includes:

- (1) Upper backer plate with integrated alignment pins and insulating tape
- (2) Lower backer plate with threaded holes and insulating tape
- (3) Flathead M2 screws

Depending on pin count, the Upper Backer is offered in two (2) thickness options – 1.07mm & 1.85mm

Item	INTERPOSER PART NUMBER	HARDWARE SIZE	Upper Back Plate Thickness (mm)	Refer to Table
1	SPH2-SF102A	Small	1.07	1
2	SPH2-MF120A	Medium	1.07	1
3	SPH2-LF150A	Large	1.07	1
4	SPH2-SD160A	Small	1.07	1
5	SPH2-MD200A	Medium	1.07	1
6	SPH2-LD240A	Large	1.85	2
7	SPH2-SC250A	Small	1.07	1
8	SPH2-MC300A	Medium	1.85	2
9	SPH2-LC400A	Large	1.85	2
10	SPH2-SC384A	Small	1.07	1
11	SPH2-MC456A	Medium	1.85	2
12	SPH2-LC576A	Large	1.85	2

COMPRESSION HARDWARE (1.07mm Option)

(Example = SPH2-SC250A, 250pos → “Small” Stiffeners)

The specific backer plate layout recommendation is included in the drawing package for each SPH2 part number.

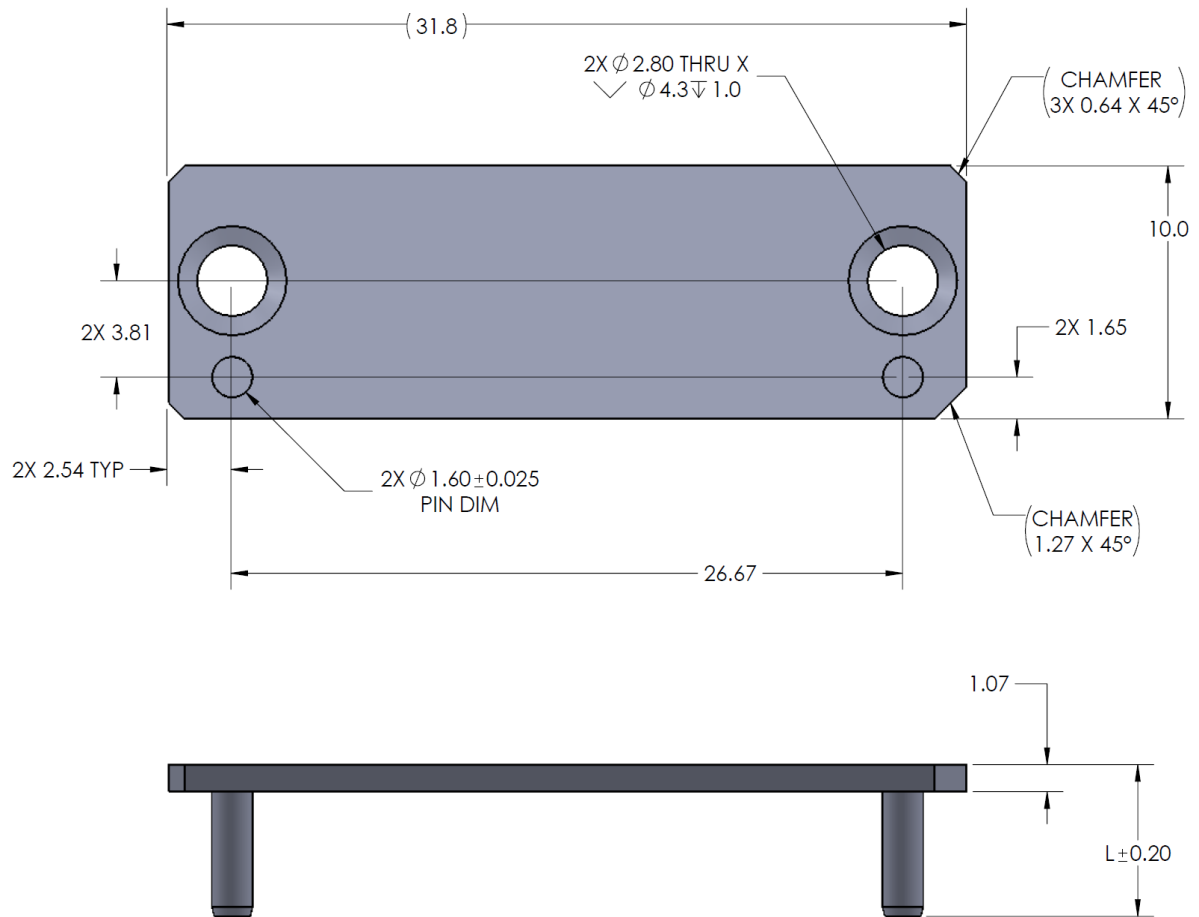
Upper Backer

DOCUMENT NUMBER: AS-000034	REV.D 4/12/2023	SPH2 Family of Standard Interposers	AUTHOR: WT	Page 9 of 15
--------------------------------------	---------------------------	--	----------------------	------------------------

COMPRESSION HARDWARE (1.85mm Option)

(Example = SPH2-MC300A, 300pos → “Medium” Stiffeners)

Neoconix has designed hardware compatible with the SPH2 interposer product family. The hardware includes:

- (1) Upper backer plate with integrated alignment pins and insulating tape
- (2) Lower backer plate with threaded holes and insulating tape
- (3) Flathead M2 screws

The specific backer plate layout recommendation is included in the drawing package for each SPH2 part number.

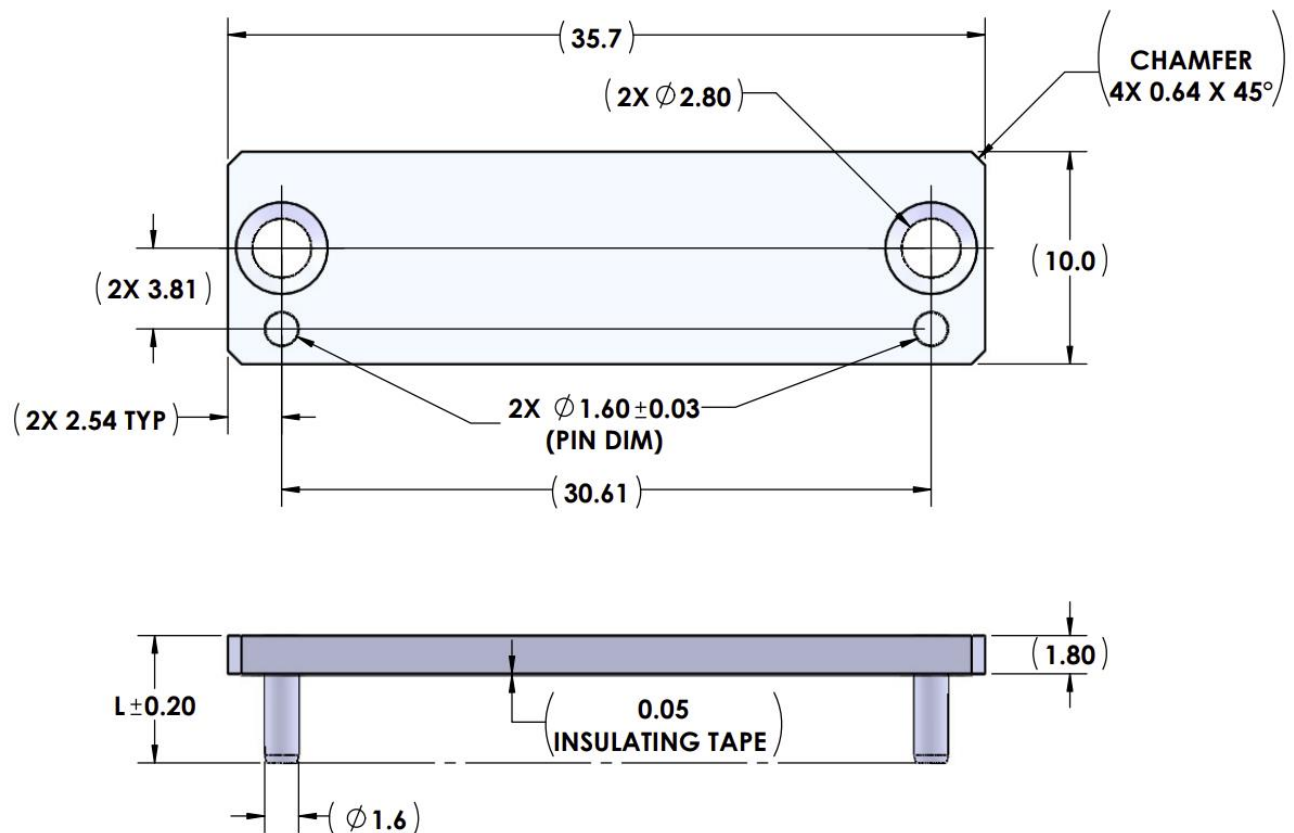

DOCUMENT NUMBER: AS-000034	REV.D 4/12/2023	SPH2 Family of Standard Interposers	AUTHOR: WT	Page 10 of 15
--------------------------------------	---------------------------	--	----------------------	-------------------------

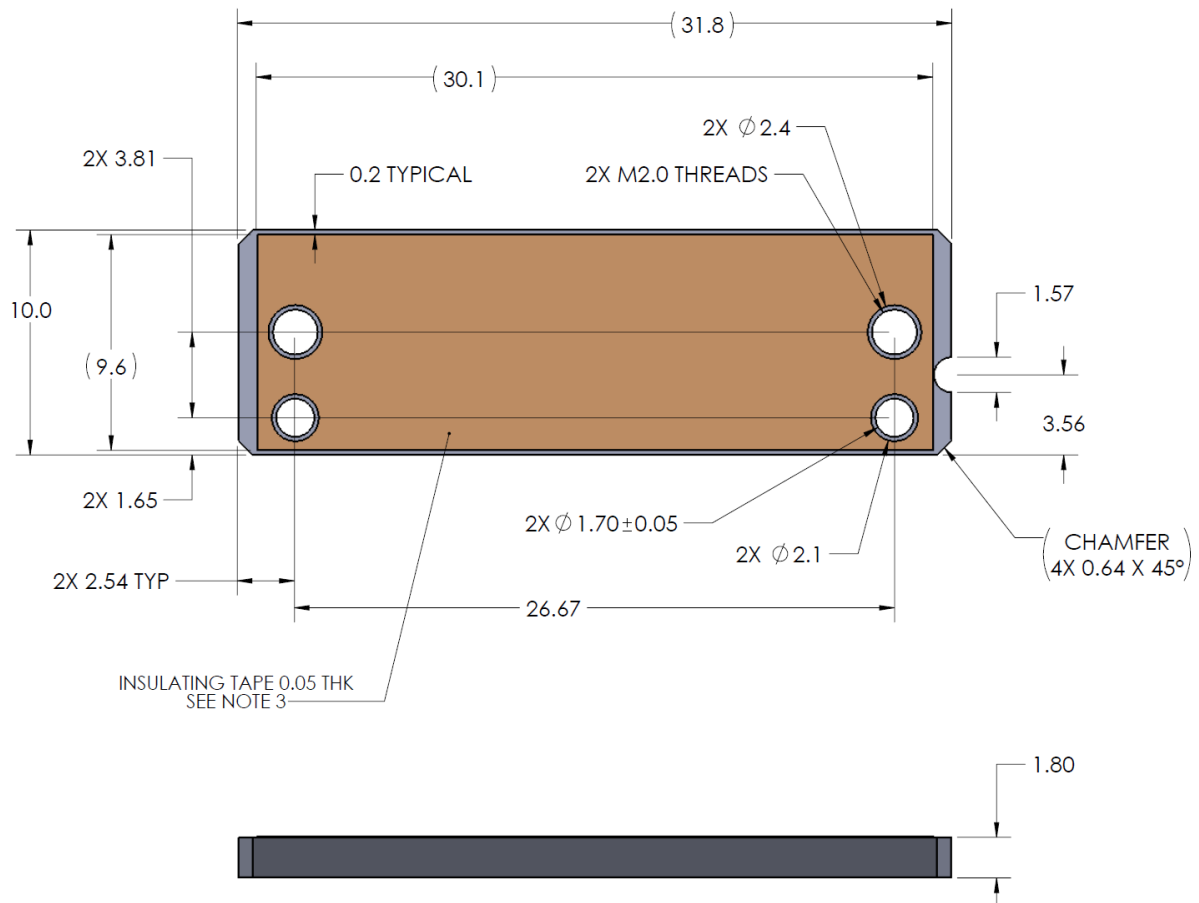

Lower Backer

Hardware Size	Lower Back Part Number	Length (mm)	Width (mm)	Thickness (mm)
Small	B01-000629	31.8	10	1.8
Medium	B01-000628	35.7		
Large	B01-000627	41.9		

Several pin/screw lengths are available, depending on the overall assembly thickness. The table below shows the recommended pin/screw length as a function of stack-up thickness. These recommendations are based on achieving at least 3 full threads of engagement (1.2mm) into the lower backer. In some cases, the pins and tails of the screws may protrude underneath the lower backer. If that is not allowable in your design, then a custom screw and pin length may be required.

**Table 1
(1.07mm Upper Backer)**

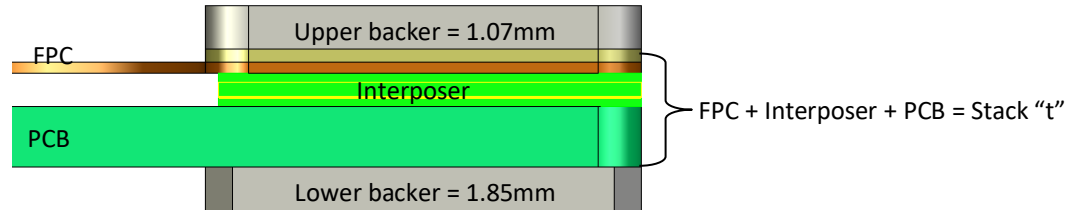

Recommended Pin & Screw Length

Stack "t" (mm)	Recommended Screw & Pin Length (mm)	P/N Suffix	Upper Backer P/N (Small)	Upper Backer P/N (Medium)	Upper Backer P/N (Large)	M2 Flathead Screw
<2.8	5 mm	L050	B01-000625-L050	B01-000624-L050	B01-000623-L050	B01-000738
2.8 - 3.7	6 mm	L060	B01-000625-L060	B01-000624-L060	B01-000623-L060	B01-000739
3.8 - 4.7	7 mm	L070	B01-000625-L070	B01-000624-L070	B01-000623-L070	B01-000740
4.8 - 5.7	8 mm	L080	B01-000625-L080	B01-000624-L080	B01-000623-L080	B01-000741
5.8 - 6.7	9 mm	L090	B01-000625-L090	B01-000624-L090	B01-000623-L090	B01-000742
6.8 - 7.7	10 mm	L100	B01-000625-L100	B01-000624-L100	B01-000623-L100	B01-000743
7.8 - 8.7	11 mm	L110	B01-000625-L110	B01-000624-L110	B01-000623-L110	B01-000744
8.8 - 9.7	12 mm	L120	B01-000625-L120	B01-000624-L120	B01-000623-L120	B01-000745

**Table 2
(1.85mm Upper Backer)**

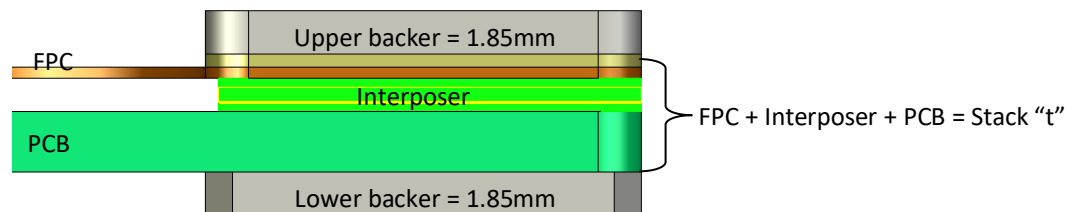

Recommended Pin & Screw Length

Stack "t" (mm)	Recommended Screw & Pin Length (mm)	P/N Suffix	Top Stiffener P/N (Small)	Top Stiffener P/N (Medium)	Top Stiffener P/N (Large)	M2 Flathead Screw
<2.8	6mm	L060	B01-000839-L060	B01-000840-L060	B01-000841-L060	B01-000739
2.8 - 3.7	7mm	L070	B01-000839-L070	B01-000840-L070	B01-000841-L070	B01-000740
3.8 - 4.7	8mm	L080	B01-000839-L080	B01-000840-L080	B01-000841-L080	B01-000741
4.8 - 5.7	9mm	L090	B01-000839-L090	B01-000840-L090	B01-000841-L090	B01-000742
5.8 - 6.7	10mm	L100	B01-000839-L100	B01-000840-L100	B01-000841-L100	B01-000743
6.8 - 7.7	10mm	L110	B01-000839-L110	B01-000840-L110	B01-000841-L110	B01-000744
7.8 - 8.7	12mm	L112	B01-000839-L120	B01-000840-L112	B01-000841-L112	B01-000745

DOCUMENT NUMBER: AS-000034	REV.D 4/12/2023	SPH2 Family of Standard Interposers	AUTHOR: WT	Page 12 of 15
--------------------------------------	---------------------------	--	----------------------	-------------------------

For the upper backer, the “Lxxx” extension defines the length of the alignment pins contained in the backer. For example L090 would have a 9.0mm pin length.

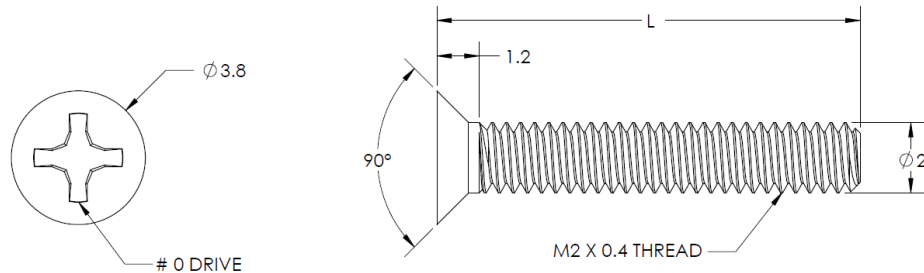

Part Number	L
B01-000738	5 mm
B01-000739	6 mm
B01-000740	7 mm
B01-000741	8 mm
B01-000742	9 mm
B01-000743	10 mm
B01-000744	11 mm
B01-000745	12 mm

Screw Reference Drawing (see drawing # B01-000737 for more detail)

ASSEMBLY INSTRUCTIONS

The proper assembly sequence is as follows:

IMPORTANT: Handle interposers only by edges, and avoid touching PCBeam contact elements. Likewise, avoid touching (and potentially contaminating) the gold mating pads on PCB & FPC. The use of latex gloves is recommended.

1. Temporarily insert *Upper Backer* onto the interposer side (top side) of the *Lower PCB*.
2. Remove protective lining on *Lower Backer* to expose underlying adhesive.
3. Using the alignment pins from *Upper Backer* as a guide, carefully attach the *Lower Backer* onto the bottom side of the *Lower PCB*. Press firmly to engage the adhesive.
4. Remove the *Upper Backer* from the *Lower PCB*
5. Insert the *Upper Backer* over the *Upper FPC* (or PCB), using the integrated dowel pins for alignment.
6. Slip the interposer onto the pad-side of the *Upper FPC*, using the dowel pins for alignment.
7. Attach the flex/interposer/backer assembly to the *Lower PCB/backer*, using the dowel pins for alignment.
8. While applying finger pressure on the center of the *Upper Backer*, attach the two screws from the *Upper Backer* into the threaded *Lower Backer* to secure the assembly together. The recommended starting torque is 12 - 16 oz*in (0.9 – 1.2 kg*cm).
 - a. The torque setting can be adjusted as needed for a specific design. The interposer is designed to be fully compressed such that no air gap should be visible between interposer and PCB/FPC at the screw points. Some minor bowing in the center is allowable.

Compression hardware can be custom designed when desired. Please ensure that the hardware solution provides sufficient rigidity assuming 0.25N - 0.55N of contact force (depending on pitch, as specified on page 3) is applied at each of the contact element positions. For example, the SPH2-SC250A interposer would exert approximately 250 positions x 0.30N/position = 75N (or 16.9 Lbs) of normal force.

DOCUMENT NUMBER: AS-000034	REV.D 4/12/2023	SPH2 Family of Standard Interposers	AUTHOR: WT	Page 13 of 15
--------------------------------------	---------------------------	--	----------------------	-------------------------

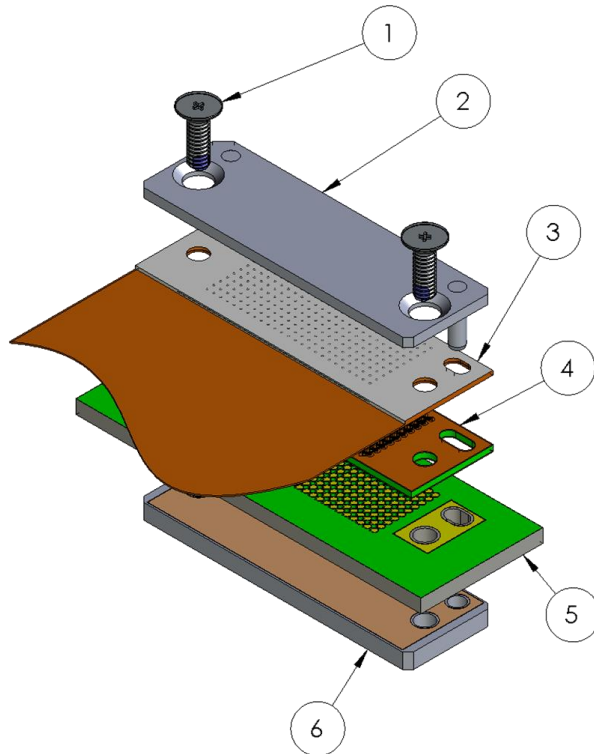
**Assembly Items:**

1. *M2 Mounting Screws*
2. *Upper Backer with Integrated Dowel Pins*
3. *FPC*
4. *PCBeam™ Interposer*
5. *PCB*
6. *Lower Backer*

DOCUMENT NUMBER: AS-000034	REV.D 4/12/2023	SPH2 Family of Standard Interposers	AUTHOR: WT	Page 14 of 15
--------------------------------------	---------------------------	--	----------------------	-------------------------

HANDLING GUIDELINES

- The use of latex gloves is recommended when handling interposers. As with any normal force connector, avoid touching contact tips and handle the product only by its edges.
- When clamping the assembly together, please ensure that the force is applied uniformly. Force should be applied vertically through the z-axis and not in an angled direction.
- Cleaning is typically not needed if the product is kept in original packaging. When necessary, cleaning can be employed with the use of compressed air. Direct the flow of air in the direction that the contact elements are pointing. Cleaning can also be performed with an ultrasonic bath of isopropyl alcohol (IPA). A 5-minute soak can be followed by a 10-minute bake at 65°C.
- When not in use, please keep product stored in original packaging.

ORDERING INFO

To obtain a quotation, please contact the Neoconix sales office at sales@neoconix.com or 408-530-9393. The SPH2 interposers, upper backers, lower backers, and screws should be ordered separately.

Custom interposers and hardware are also available from Neoconix. Please contact the factory to request a quotation.

Corporate Headquarters:

Neoconix, Inc.
 4020 Moorpark Ave., #108
 San Jose, CA 95117
 (408) 530-9393 (phone)
 (408) 530-9383 (fax)
<http://www.neoconix.com>

REVISION HISTORY

Rev	Date	ECN	Description
Rev A	12/21/2017	N/A	Initial release.
Rev B	05/30/2018	1208	Update top stiffener plate part number, stiffener drawing, typical load
Rev C	01/23/2019	1263	Update part numbers, drawings, etc. Add 0.65mm pitch configuration.
Rev D	04/13/2023	1316	Added 5 new SPH2 designs, hardware updated

DOCUMENT NUMBER: AS-000034	REV.D 4/12/2023	SPH2 Family of Standard Interposers	AUTHOR: WT	Page 15 of 15
--------------------------------------	---------------------------	--	----------------------	-------------------------