

92-Position LGA/LGA PCBeam™ Connector

Neoconix P/N: BBX0092CMMHFAU00

FEATURES

- High density 0.7424mm area-array pitch
- Low profile, 1.55 mm mated height
- PCBeam™ high reliability LGA spring contacts
- Hard gold-plated contact interface
- RoHS 2011/65/EU (RoHS2) compliant

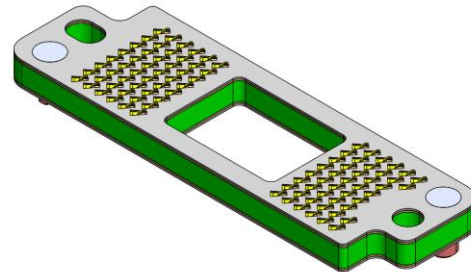

OVERVIEW

The PCBeam™ 92 Position Connector is an interconnect solution for the Texas Instruments S315 DMD. Featuring Neoconix's patented PCBeam™ interconnect technology, this product offers high performance and high reliability in an extremely compact form factor, a heat-sink opening, and features for precise alignment of the connector to the DMD and main PC Board.

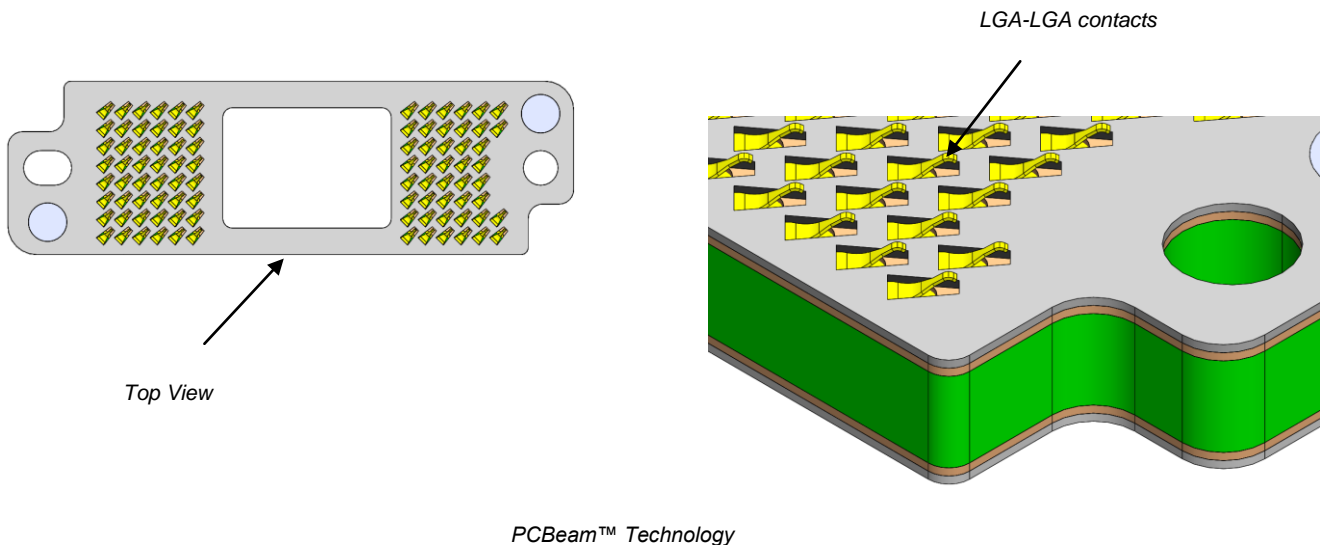

DOCUMENT NUMBER: AS-000029	REV. D 10/14/2021	92-pin Interposer	AUTHOR: WT	Page 1 of 6
--------------------------------------	-----------------------------	-------------------	----------------------	-----------------------

CROSS REFERENCE INFO:

- TI Interposer Drawing: 2515010
- TI DMD Drawing: 2512400

ORDERING INFORMATION:

- Part Number: BBX0092CMMHFAU00
- Production Packaging: Vacuum formed Low Profile Matrix Trays
- Minimum Production Order Quantity: 3,150
- Lead Time: 8 weeks ARO

SPECIFICATIONS
MECHANICAL

Contact Configuration.....	single-beam
Contact Pitch.....	0.7424mm x 0.7424mm
Contact Count.....	92
Target Load / Contact.....	30 ± 10 grams
Contact Deflection.....	0.16 mm typical per side

ELECTRICAL

Current Rating.....	0.5A per position
Resistance.....	< 50mΩ per position
Dielectric Withstanding Voltage.....	100VDC

ENVIRONMENTAL

Operating Temperature.....	-20°C to 85°C
Storage Temperature.....	-40°C to 85°C
Heat aging.....	85°C, 96hrs,
High temperature Humidity.....	96 hrs, 90% RH, 60°C
Low temperature/ Ambient Humidity	96 hrs, -25 °C
Temperature Cycling	32 cycles, -25°C to 60°C
Thermal Shock.....	32 cycles, -25°C to 60°C
Salt Spray.....	48hrs, 5% mist
Random Vibration.....	10-55Hz rms, 3 axes, 2hrs/axis
Insertions.....	50 mating cycles

MATERIALS

Core Dielectric.....	FR4
Contact Elements.....	Copper alloy
Contact Plating.....	hard Au over Ni
Surface Insulator.....	polyimide

NOTE: Specifications are subject to change without notice.

DIMENSIONAL INFORMATION

DOCUMENT NUMBER: AS-000029	REV. D 10/14/2021	92-pin Interposer	AUTHOR: WT	Page 2 of 6
--------------------------------------	-----------------------------	-------------------	----------------------	-----------------------

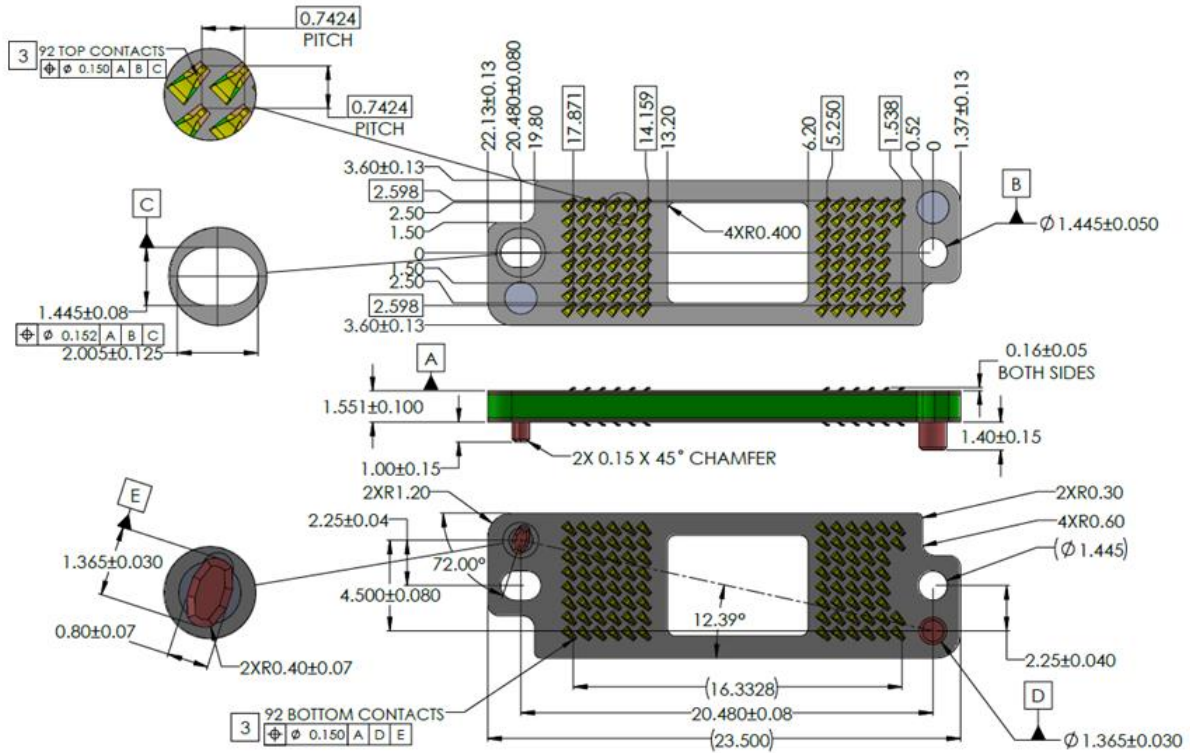

NOTES:(UNLESS OTHERWISE SPECIFIED)

- 1.INTERPRET DRAWING PER ASME Y14.5-94.
- 2.COMPLIANT WITH RoHS DIRECTIVE 2002/95/EC
- 3 CENTER MARKS OF CONTACT POSITIONS ARE FOR COMPRESSED

DIMENSIONS ARE IN mm
TOLERANCES (unless otherwise specified):

ANGULAR: ± 2 degree
 LINEAR: .X ± 0.15 [0.06]
 .XX ± 0.10 [0.04]
 .XXX ± 0.05 [0.02]

Note: This example information is for reference only. Please refer to the latest product drawing.

RECOMMENDED PCB LAYOUT

DOCUMENT NUMBER: AS-000029	REV. D 10/14/2021	92-pin Interposer	AUTHOR: WT	Page 3 of 6
--------------------------------------	-----------------------------	-------------------	----------------------	-----------------------

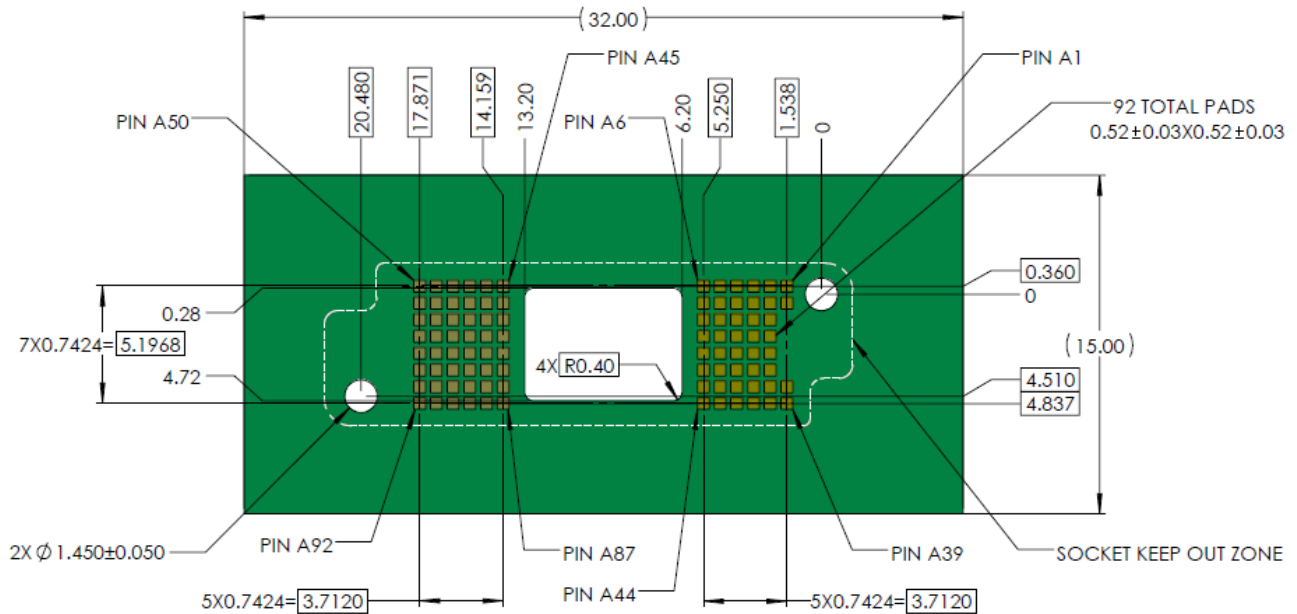
NOTE(UNLESS OTHERWISE SPECIFIED):

1. PADS TO BE ELECTROLESS NICKEL/IMMERSION GOLD (ENIG) PLATED
2. VIAS IN PAD AREAS MUST BE FILLED
3. INTERPOSER OUTLINE; NO COMPONENTS ALLOWED WITHIN THIS AREA
4. ALLOWED COMPONENT AREA; MAXIMUM COMPONENT HEIGHT 1.3 mm
5. IF SOLDERMASK IS APPLIED IN THE ARRAY AREA, IT SHALL NOT PROTRUDE ABOVE THE PLANE OF THE CONTACT PAD SURFACE

DIMENSIONS ARE IN mm
TOLERANCES (unless otherwise specified):

ANGULAR: ± 2 degree
 LINEAR: .X ± 0.15 [0.06]
 .XX ± 0.10 [0.04]
 .XXX ± 0.05 [0.02]

Note: This information is for reference only. Please refer to the latest product drawing.

ASSEMBLY & HANDLING GUIDELINES

DOCUMENT NUMBER: AS-000029	REV. D 10/14/2021	92-pin Interposer	AUTHOR: WT	Page 4 of 6
--------------------------------------	-----------------------------	-------------------	----------------------	-----------------------

- The use of latex gloves is recommended when handling interposers. As with any normal force connector, avoid touching contact tips and handle the product only by its edges.
- When clamping the module, PCB, or FPC onto the connector, please ensure that the force is applied uniformly. Force should be applied vertically through the z-axis and not in an angled direction.
- Cleaning is typically not needed if the product is kept in original packaging. When necessary, cleaning can be employed with the use of compressed air. Direct the flow of air in the direction that the contact elements are pointing. Cleaning can also be performed with an ultrasonic bath of isopropyl alcohol (IPA). A 5 minute soak can be followed by a 10 minute bake at 65°C.
- When not in use, please keep product stored in original packaging.

PACKAGING INFO

Production parts are provided in low profile vacuum formed trays. Each tray holds 50 pcs at 60 trays per carton

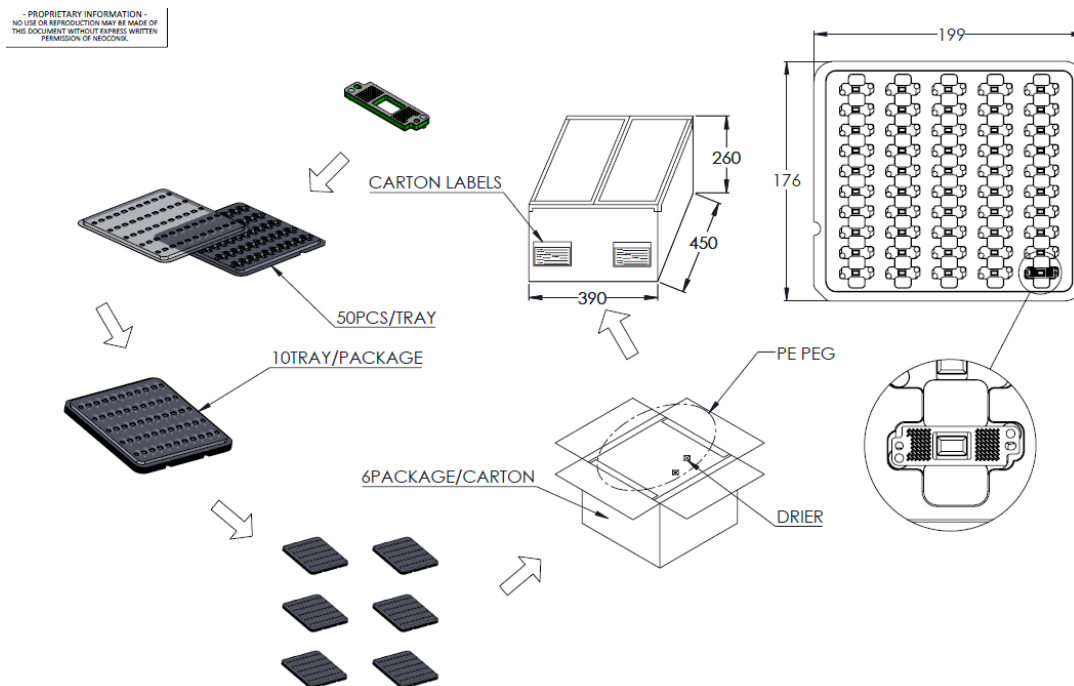

NOTE(UNLESS OTHERWISE SPECIFIED):

1.COMPONENT LOAD PER TRAY : 50PCS

10 TRAY/PACKAGE:500 PCS

6 PACKAGE/CARTON: 450mm X 390mm X 260mm.

TOTAL: 3000PCS/CARTON

2.MATERIAL:TRANSPARENT POLYSTYRENE(PS).

DOCUMENT NUMBER: AS-000029	REV. D 10/14/2021	92-pin Interposer	AUTHOR: WT	Page 5 of 6
--------------------------------------	-----------------------------	-------------------	----------------------	-----------------------

ORDERING INFO

To obtain a quotation, please contact the Neoconix sales office at sales@neoconix.com or 408-530-9393. Please include the part number(s) of interest.

Custom interposers and hardware are also available from Neoconix.

Corporate Headquarters:

Neoconix, Inc.
4020 Moorpark Ave., #108
San Jose, CA 95117 USA

Phone: +1 (408) 530-9393

Fax: +1 (408) 530-9383

Email: sales@neoconix.com

UR: <http://www.neoconix.com>

China Contact: David Chen

Phone: +1 (408) 768-4135

Email: sales@neoconix.com

REVISION HISTORY

Rev A	08/11/2017	Production Release
Rev B	09/10/2017	Updated Packaging Info and Ordering Info.
Rev C	03/20/2018	Updated Packaging Info and Ordering Info.
Rev D	10/14/2021	Updated contact design to single tip

DOCUMENT NUMBER: AS-000029	REV. D 10/14/2021	92-pin Interposer	AUTHOR: WT	Page 6 of 6
--------------------------------------	-----------------------------	-------------------	----------------------	-----------------------