

- PROPRIETARY INFORMATION -
NO USE OR REPRODUCTION MAY BE MADE OF
THIS DOCUMENT WITHOUT EXPRESS WRITTEN
PERMISSION OF NEOCONIX.

REVISIONS				
REV	ECN	DESCRIPTION	DATE	APPROVED
A	1231	PRODUCTION RELEASE	04-10-2019	WES TAO
B	1277	CHANGED TO PHILLIPS HEAD SCREW	10-30-2020	WES TAO
C	1285	ADDED STIFFENER BREAK TABS	03-01-2021	WES TAO

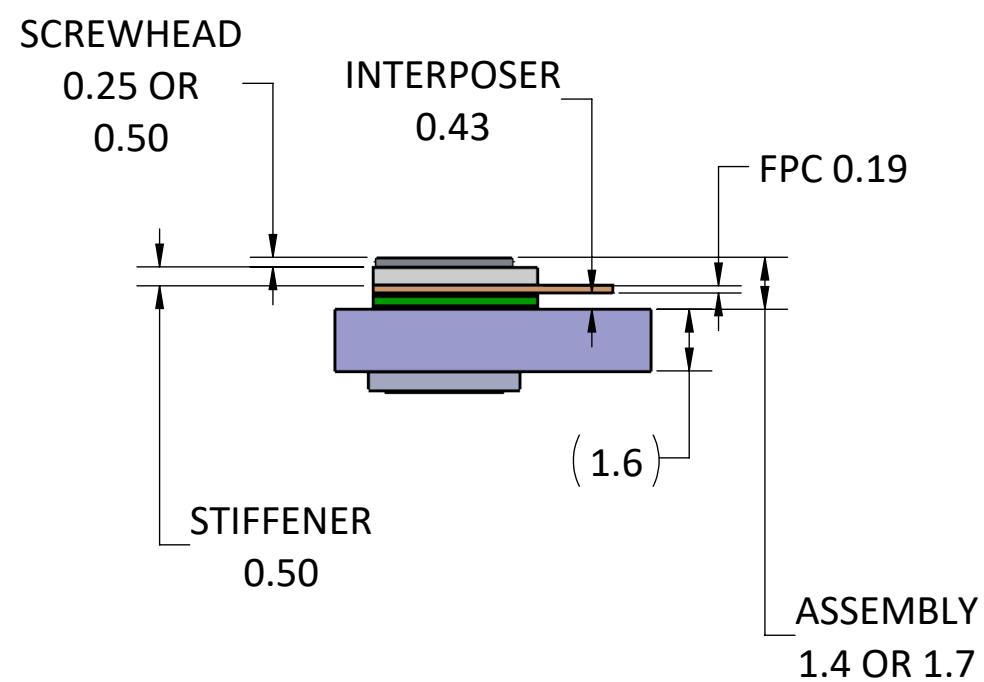
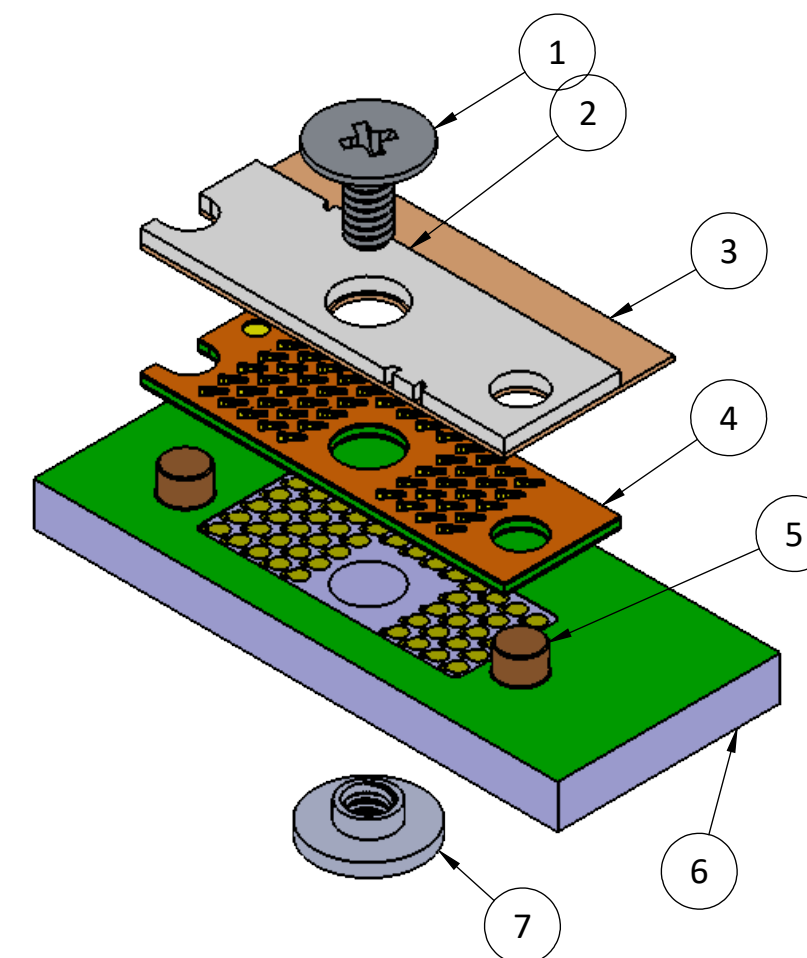
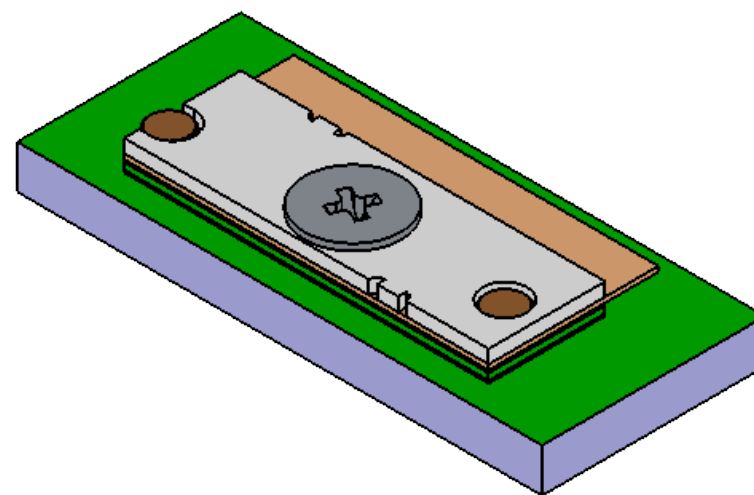
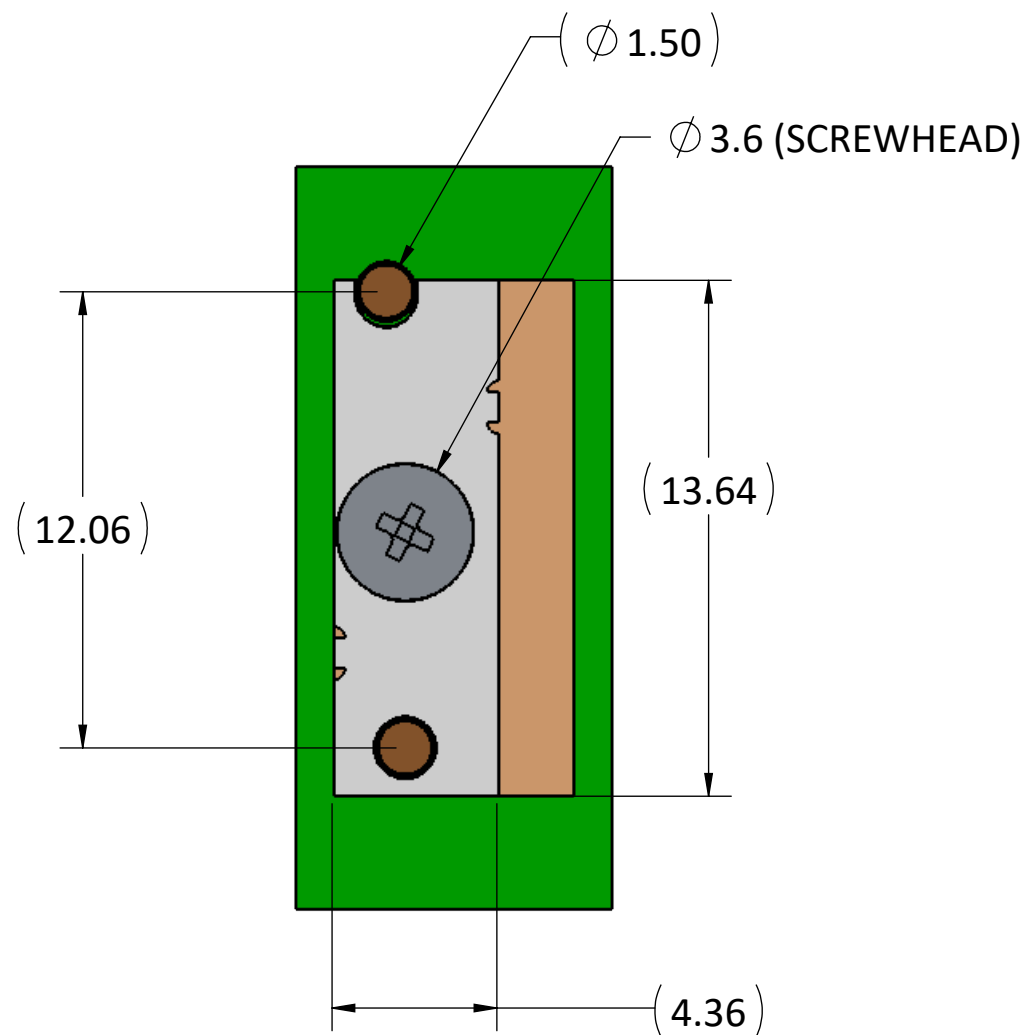

ITEM	DESCRIPTION	NEOCONIX P/N	QTY per ASSY
1*	SCREW, M1.4, L=3MM	B01-000614	1
	SCREW, M1.4, L=4MM	B01-000657	
	SCREW, M1.4, L=5MM	B01-000658	
2	STIFFENER	LPM-049A-STF	1
3	FPC	CUSTOM UPON REQUEST	1
4	INTERPOSER	LPM-049A	1
5	ALIGNMENT PIN	B01-000589	2
6	PCB	N/A - CUSTOMER SUPPLIED	1
7	SMT NUT, M1.4	B01-000581	1

* SEE AS-000021 FOR RECOMMENDED SCREW LENGTH.
ALL ITEMS ORDERED SEPARATELY.

<p>4020 MOORPARK AVENUE #108 SAN JOSE, CA 95117 USA TEL: 408-530-9393 FAX: 408-530-9383</p>	DIMENSIONS ARE IN MM [INCH] .X ± .XX ± .XXX ± ANGLE: NO DEC ± .X ± .XX ±	MATERIAL: FINISH: DRAWN BY: JASON WU 03-19-2015 CHECKED BY: ENGR APPR: MFG APPR: QA APPR:	TITLE: LPM ASSEMBLY, 49 POSITIONS LGA-LGA DWG NUMBER: LPM-049A-ASY
		SIZE: B+	REV: C
	SCALE: 5:1		SHEET 1 OF 5
	THIRD ANGLE		

- PROPRIETARY INFORMATION -
NO USE OR REPRODUCTION MAY BE MADE OF
THIS DOCUMENT WITHOUT EXPRESS WRITTEN
PERMISSION OF NEOCONIX.

REVISIONS				
REV	ECN	DESCRIPTION	DATE	APPROVED
A	1231	PRODUCTION RELEASE	04-10-2019	WES TAO

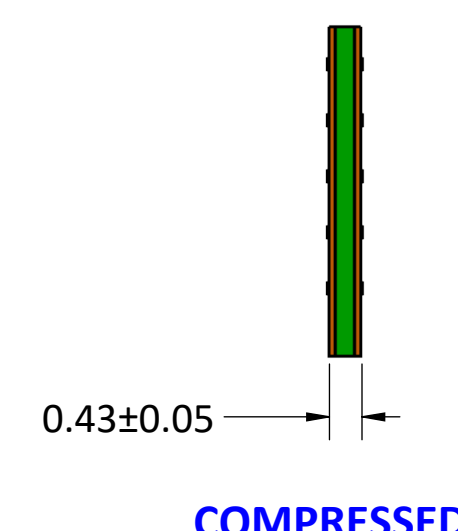
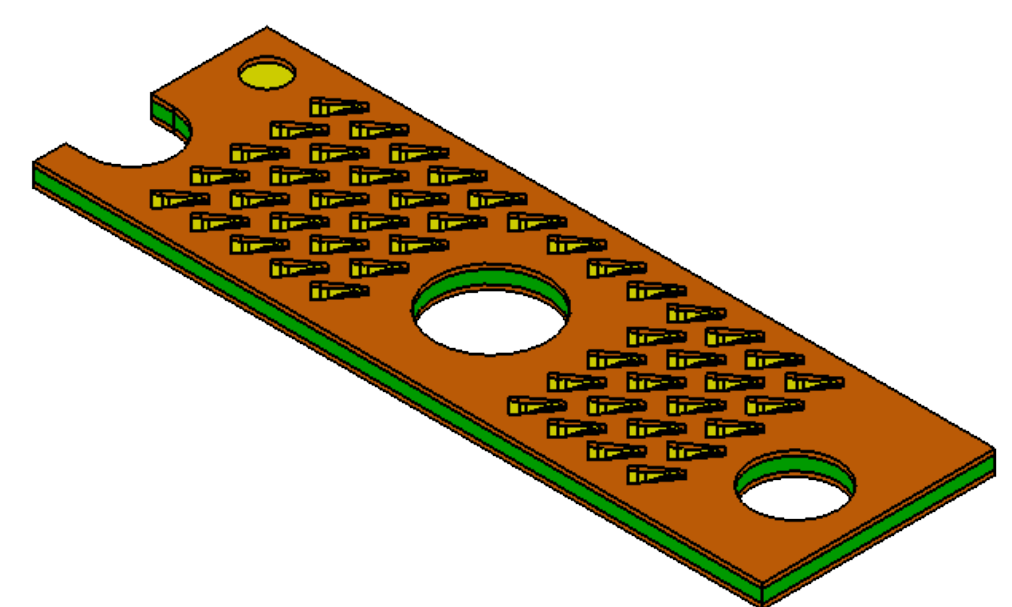
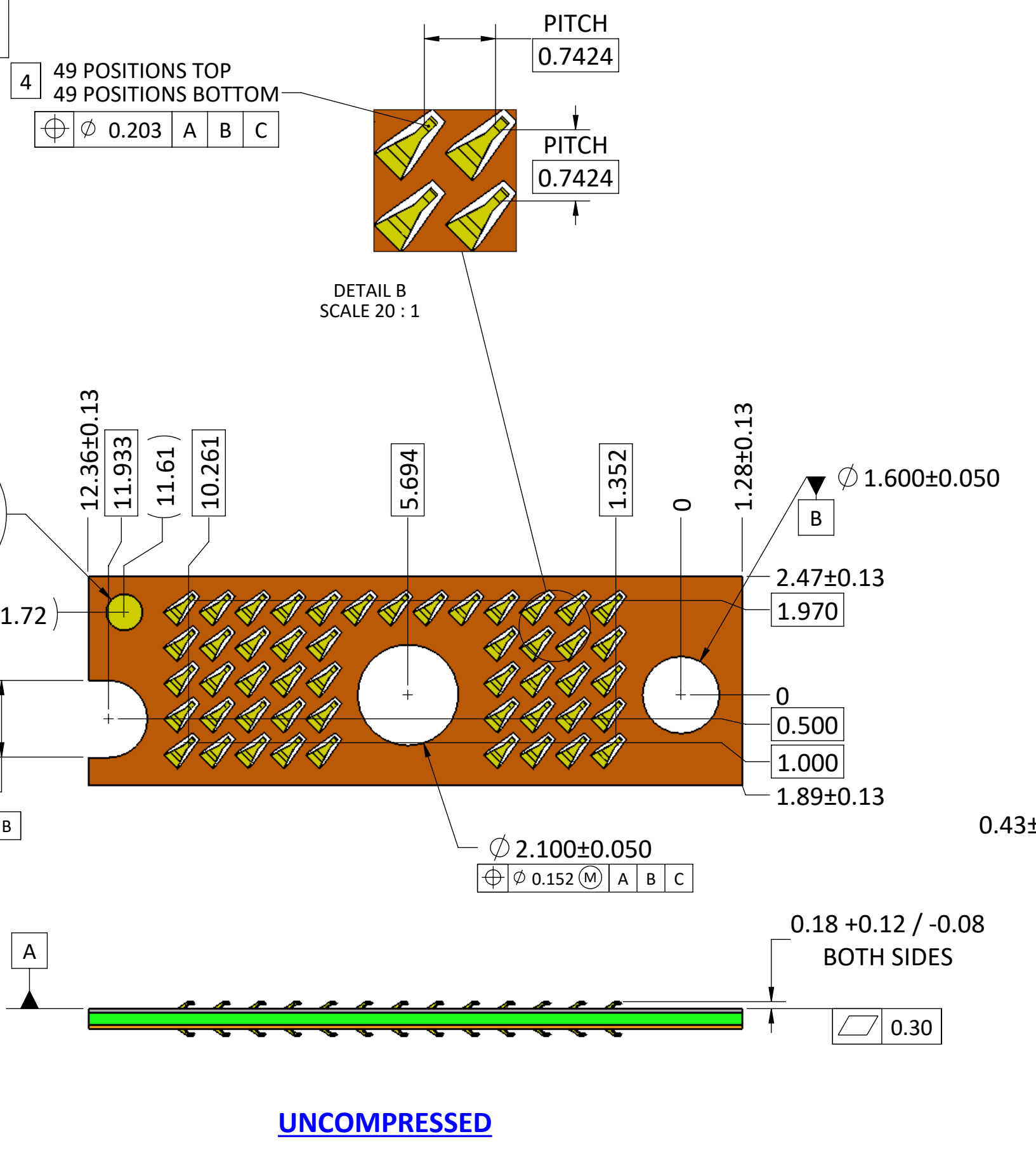

UNCOMPRESSED

NOTES (UNLESS OTHERWISE SPECIFIED):

1. INTERPRET DRAWING PER ASME Y14.5M-1994.
2. HALOGEN-FREE PER IPC-4101B.
3. COMPLIANT WITH RoHS DIRECTIVE 2011/65/EU.
4. CENTER MARKS OF CONTACT POSITIONS ARE FOR COMPRESSED STATE

<p>4020 MOORPARK AVENUE #108 SAN JOSE, CA 95117 USA TEL: 408-530-9393 FAX: 408-530-9383</p>	<p>DIMENSIONS ARE IN MM [INCH]</p> <p>.X \pm 0.13 [.005] .XX \pm 0.08 [.003] .XXX \pm 0.025 [.001]</p> <p>ANGLE: NO DEC \pm 1° .X \pm 0.5° .XX \pm 0.25°</p> <p>THIRD ANGLE</p>	<p>MATERIAL: SEE NOTES</p> <p>FINISH: SEE NOTES</p> <p>DRAWN BY: Jason Wu 03-19-2015</p> <p>CHECKED BY: Woody Maynard 03-19-2015</p> <p>ENGR APPR:</p> <p>MFG APPR:</p> <p>QA APPR:</p>	<p>TITLE: LPM INTERPOSER, 49 POSITIONS LGA-LGA</p> <p>SIZE: B+</p> <p>DWG NUMBER: LPM-049A</p> <p>REV: A</p>
	<p>SCALE: 10:1 SHEET 2 OF 5</p>		

REVISIONS				
REV	ECN	DESCRIPTION	DATE	APPROVED
A	1231	PRODUCTION RELEASE	04-10-2019	WES TAO

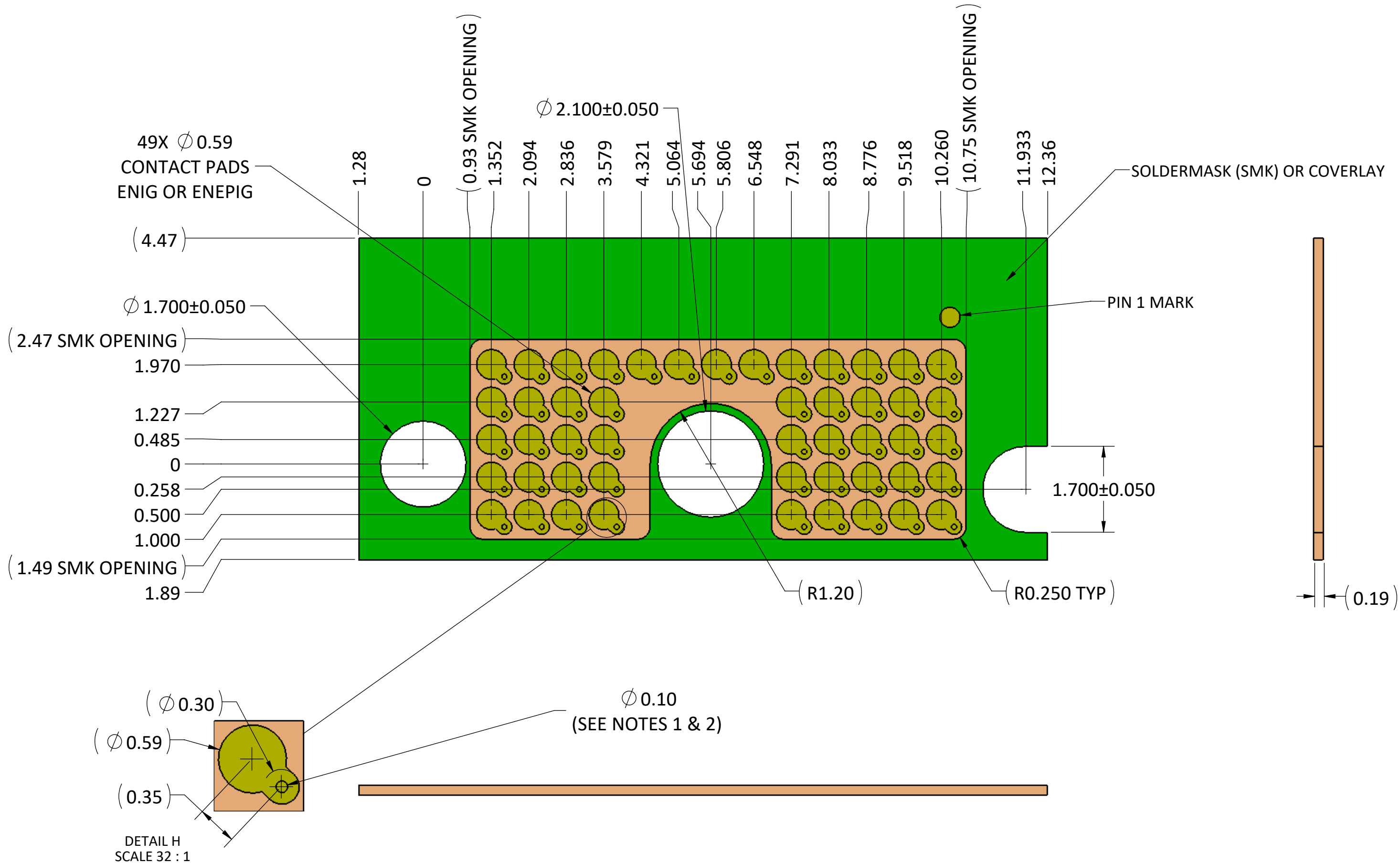

NOTES:

1. THE PAD GEOMETRY SHOWN ASSUMES A BLIND VIA STACK-UP. IF A THRU-HOLE VIA IS NEEDED, IT IS ACCEPTABLE TO ROTATE THE POSITION OF THE VIAS AS NEEDED TO AVOID INTERFERENCE WITH THE BACK SIDE NUT SOLDER PAD.
2. IF THE VIA NEEDS TO BE LOCATED WITHIN THE 0.59MM PAD DIAMETER, IT MUST BE FILLED, PLATED, AND PLANARIZED WITH 25UM MAX DIMPLE.

neconix

4020 MOORPARK AVENUE #108
SAN JOSE, CA 95117 USA
TEL: 408-530-9393 FAX: 408-530-9383

DIMENSIONS ARE IN MM [INCH]

.X \pm 0.13 [.005]
.XX \pm 0.08 [.003]
.XXX \pm 0.025 [.001]

ANGLE: NO DEC \pm 1°
.X \pm 0.5°
.XX \pm 0.25°

THIRD ANGLE

MATERIAL:		FINISH:	
DRAWN BY: JASON WU	03-19-2015	CHECKED BY:	
ENGR APPR:		MFG APPR:	
QA APPR:			

TITLE: RECOMMENDED FPC LAYOUT		REV	
LPM 49 POSITIONS		A	
DWG NUMBER: LPM-049A-FPC	SCALE: 10:1	SHEET 3 OF 5	

REVISIONS				
REV	ECN	DESCRIPTION	DATE	APPROVED
A	1231	PRODUCTION RELEASE	04-10-2019	WES TAO

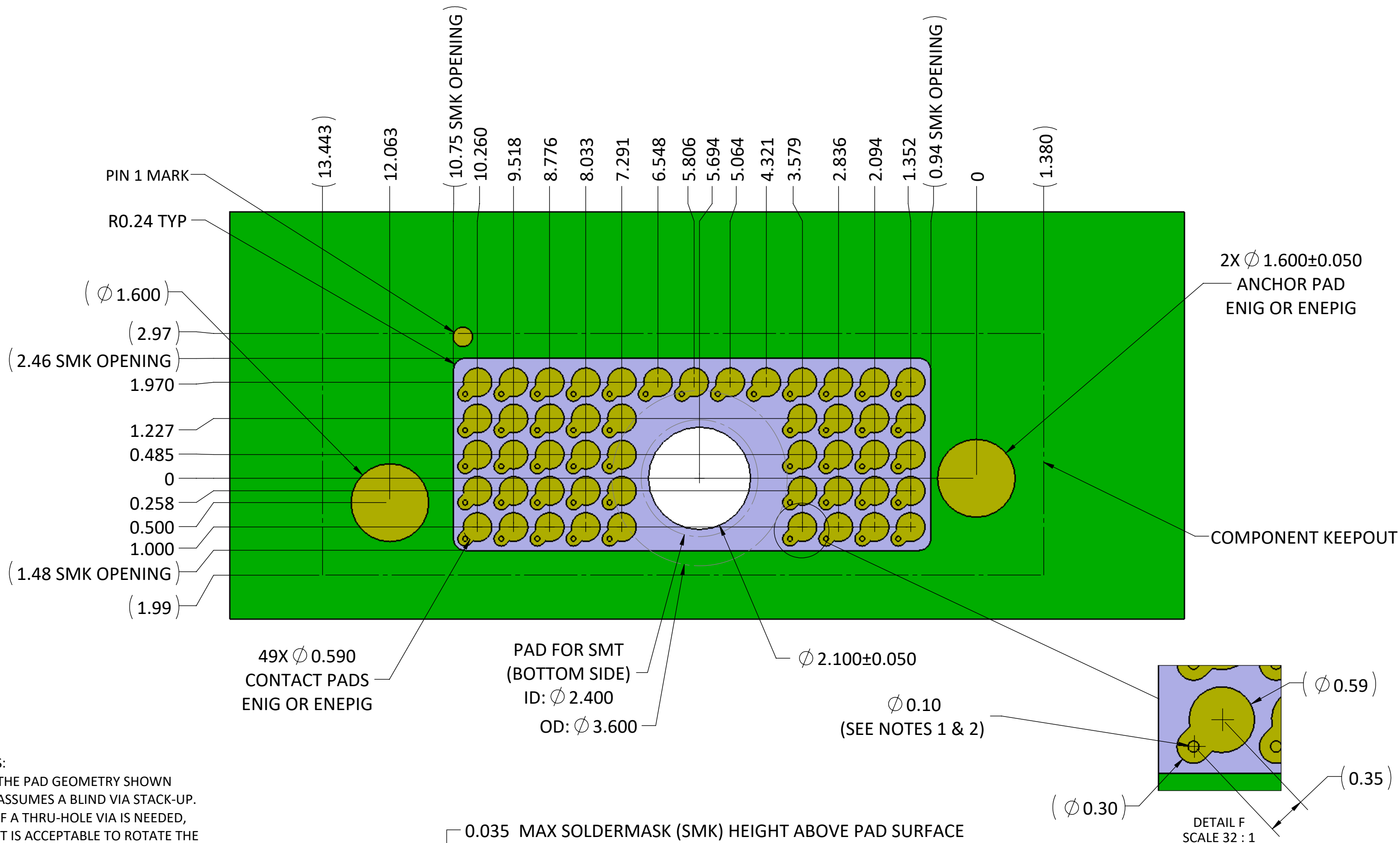

NOTES:

1. THE PAD GEOMETRY SHOWN ASSUMES A BLIND VIA STACK-UP. IF A THRU-HOLE VIA IS NEEDED, IT IS ACCEPTABLE TO ROTATE THE POSITION OF THE VIAS AS NEEDED TO AVOID INTERFERENCE WITH THE BACK SIDE NUT SOLDER PAD.
2. IF THE VIA NEEDS TO BE LOCATED WITHIN THE 0.59MM PAD DIAMETER, IT MUST BE FILLED, PLATED, AND PLANARIZED WITH 25UM MAX DIMPLE.

neconix
4020 MOORPARK AVENUE #108
SAN JOSE, CA 95117 USA
TEL: 408-530-9393 FAX: 408-530-9383

DIMENSIONS ARE IN
MM [INCH]
.X ± 0.13 [.005]
.XX ± 0.08 [.003]
.XXX ± 0.025 [.001]
ANGLE: NO DEC $\pm 1^\circ$
.X $\pm 0.5^\circ$
.XX $\pm 0.25^\circ$

MATERIAL:
FINISH:
DRAWN BY: JASON WU 03-19-2015
CHECKED BY:
ENGR APPR:
MFG APPR:
QA APPR:

TITLE:
**RECOMMENDED PCB LAYOUT
LPM 49 POSITIONS**
SIZE: B+
DWG NUMBER:
LPM-049A-PCB
SCALE: 10:1 SHEET 4 OF 5

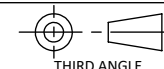

- PROPRIETARY INFORMATION -
NO USE OR REPRODUCTION MAY BE MADE OF
THIS DOCUMENT WITHOUT EXPRESS WRITTEN
PERMISSION OF NEOCONIX.

REVISIONS				
REV	ECN	DESCRIPTION	DATE	APPROVED
A	1231	PRODUCTION RELEASE	04-10-2019	WES TAO
B	1285	ADDED BREAK TABS, STD TOLS	03-01-2021	WES TAO

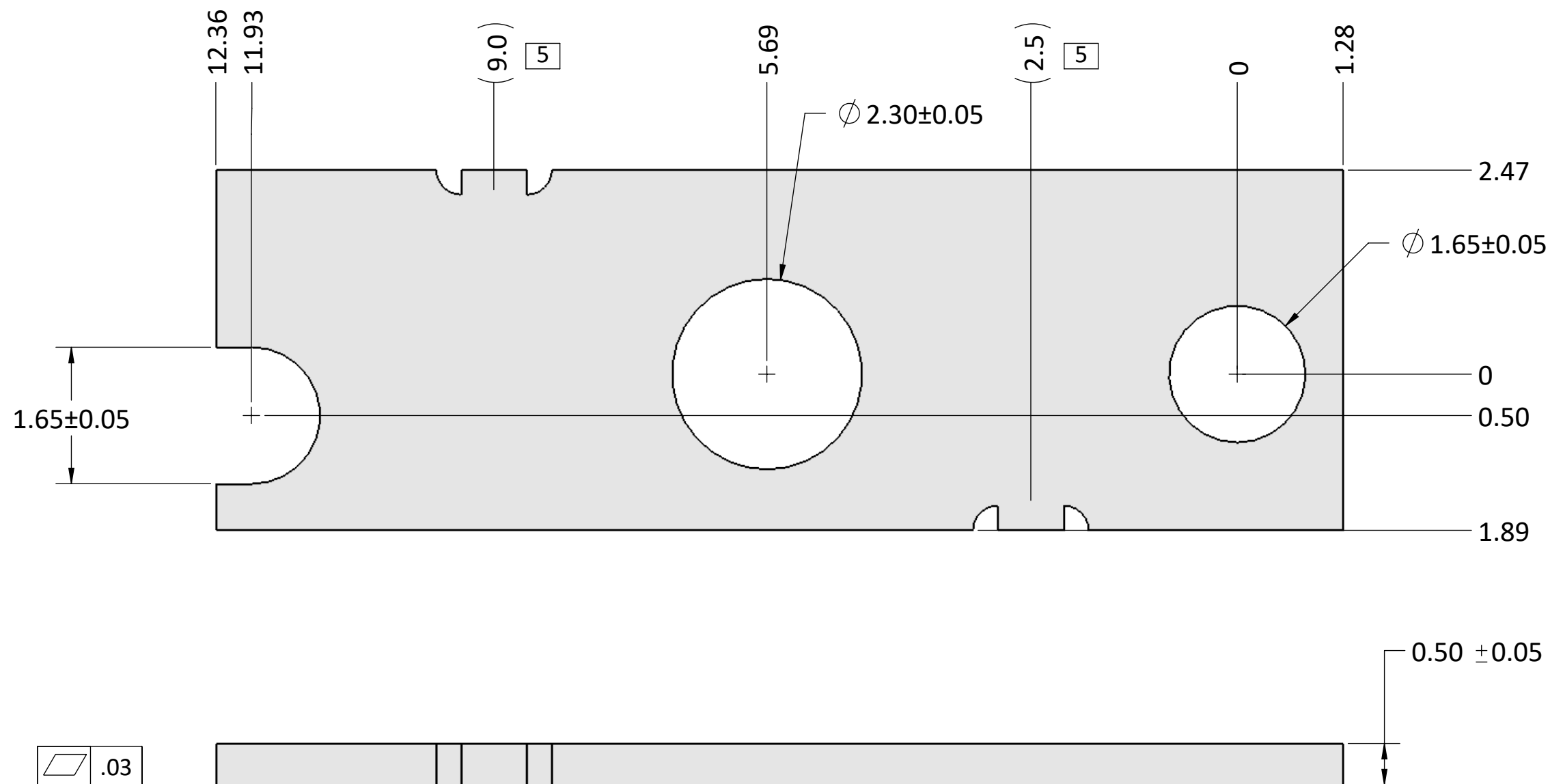

NOTES (UNLESS OTHERWISE SPECIFIED):

1. INTERPRET DRAWING PER ASME Y14.5M-1994.
2. USE THERMOSETTING ADHESIVE FILM TO ATTACH TO FPC.
3. RECOMMEND 0.15MM CLEARANCE BETWEEN EDGE OF ADHESIVE AND EDGE/HOLE FEATURES TO ACCOMODATE ADHESIVE FLOW.
4. MATERIAL: 301 SS FULL HARD
5. BREAK APPROXIMATELY AS SHOWN: NOT TO EXTEND BEYOND STIFFENER EDGE

neconix
4020 MOORPARK AVENUE #108
SAN JOSE, CA 95117 USA
TEL: 408-530-9393 FAX: 408-530-9383

DIMENSIONS ARE IN MM
.X ± 0.13
.XX ± 0.08
.XXX ± 0.025
ANGLE: NO DEC $\pm 1^\circ$
.X $\pm 0.5^\circ$
.XX $\pm 0.25^\circ$
THIRD ANGLE

MATERIAL: SEE NOTES
FINISH: SEE NOTES
DRAWN BY: JASON WU 07-31-2015
CHECKED BY:
ENGR APPR:
MFG APPR:
QA APPR:

TITLE: STIFFENER, LPM 49 POS
DWG NUMBER: LPM-049A-STF
SCALE: 10:1
SHEET 5 OF 5