

## 92-Position LGA/LGA PCBeam™ Connector

Neoconix P/N: BBX0092CMMHFAU00

### FEATURES

- High density 0.7424mm area-array pitch
- Low profile, 1.55 mm mated height
- PCBeam™ high reliability LGA spring contacts
- Bifurcated contact tips
- Hard gold-plated contact interface
- RoHS 2011/65/EU (RoHS2) compliant

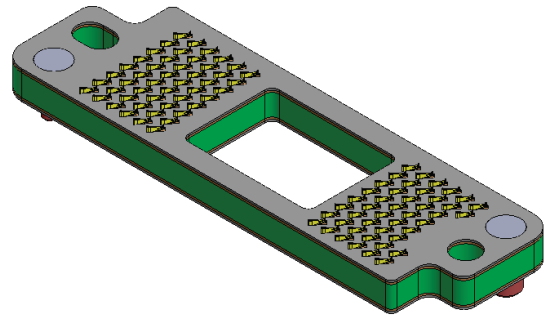

### OVERVIEW

The PCBeam™ 92 Position Connector is an interconnect solution for the Texas Instruments S315 DMD. Featuring Neoconix's patented PCBeam™ interconnect technology, this product offers high performance and high reliability in an extremely compact form factor, a heat-sink opening, and features for precise alignment of the connector to the DMD and main PC Board. A bifurcated contact design enhances the product reliability by providing an aggressive wiping during assembly.

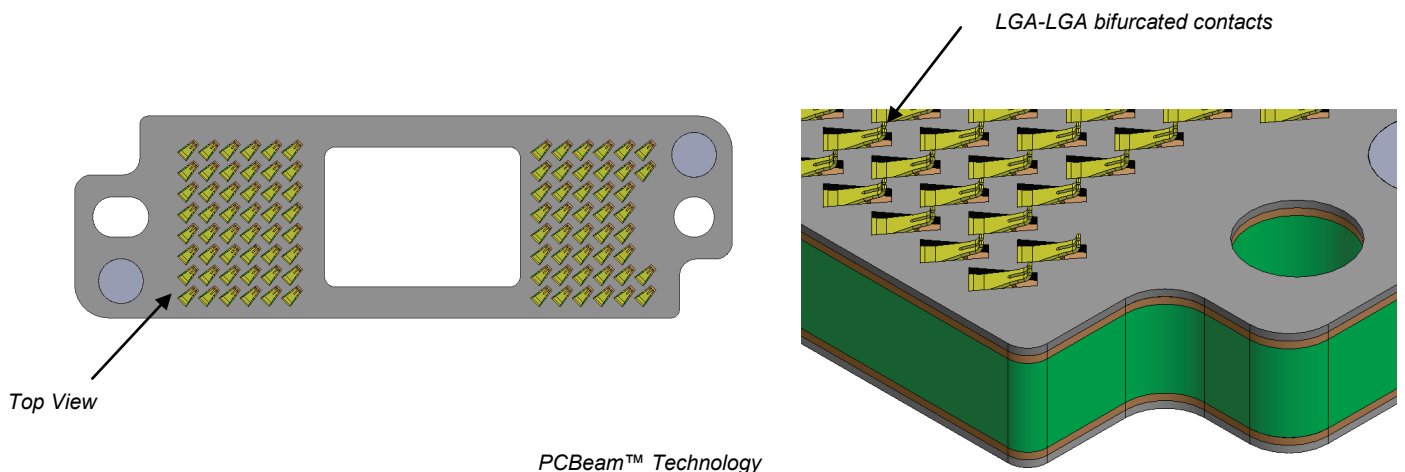

|                                      |                            |                   |                      |                       |
|--------------------------------------|----------------------------|-------------------|----------------------|-----------------------|
| <b>DOCUMENT NUMBER:</b><br>AS-000029 | <b>REV. C</b><br>3/20/2018 | 92-pin Interposer | <b>AUTHOR:</b><br>WT | <b>Page</b><br>1 of 6 |
|--------------------------------------|----------------------------|-------------------|----------------------|-----------------------|

**CROSS REFERENCE INFO:**

- TI Interposer Drawing: 2515010
- TI DMD Drawing: 2512400

**ORDERING INFORMATION:**

- Part Number: BBX0092CMMHFAU00
- Production Packaging: Vacuum formed Low Profile Matrix Trays
- Minimum Production Order Quantity: 3,150
- Lead Time: 8 weeks ARO

**SPECIFICATIONS**
**MECHANICAL**

|                            |                              |
|----------------------------|------------------------------|
| Contact Configuration..... | single-beam, bifurcated tips |
| Contact Pitch.....         | 0.7424mm x 0.7424mm          |
| Contact Count.....         | 92                           |
| Target Load / Contact..... | 30 ± 10 grams                |
| Contact Deflection.....    | 0.16 mm typical per side     |

**ELECTRICAL**

|                                      |                     |
|--------------------------------------|---------------------|
| Current Rating.....                  | 0.5A per position   |
| Resistance.....                      | < 50mΩ per position |
| Dielectric Withstanding Voltage..... | 100VDC              |

**ENVIRONMENTAL**

|   |                                |
|---|--------------------------------|
| Operating Temperature.....              | -20°C to 85°C                  |
| Storage Temperature.....                | -40°C to 85°C                  |
| Heat aging.....                         | 85°C, 96hrs,                   |
| High temperature Humidity.....          | 96 hrs, 90% RH, 60°C           |
| Low temperature/ Ambient Humidity ..... | 96 hrs, -25 °C                 |
| Temperature Cycling .....               | 32 cycles, -25°C to 60°C       |
| Thermal Shock.....                      | 32 cycles, -25°C to 60°C       |
| Salt Spray.....                         | 48hrs, 5% mist                 |
| Random Vibration.....                   | 10-55Hz rms, 3 axes, 2hrs/axis |
| Insertions.....                         | 50 mating cycles               |

**MATERIALS**

|                        |                 |
|------------------------|-----------------|
| Core Dielectric.....   | FR4             |
| Contact Elements.....  | Copper alloy    |
| Contact Plating.....   | hard Au over Ni |
| Surface Insulator..... | polyimide       |

*NOTE: Specifications are subject to change without notice.*

|                                      |                            |                   |                      |                       |
|--------------------------------------|----------------------------|-------------------|----------------------|-----------------------|
| <b>DOCUMENT NUMBER:</b><br>AS-000029 | <b>REV. C</b><br>3/20/2018 | 92-pin Interposer | <b>AUTHOR:</b><br>WT | <b>Page</b><br>2 of 6 |
|--------------------------------------|----------------------------|-------------------|----------------------|-----------------------|

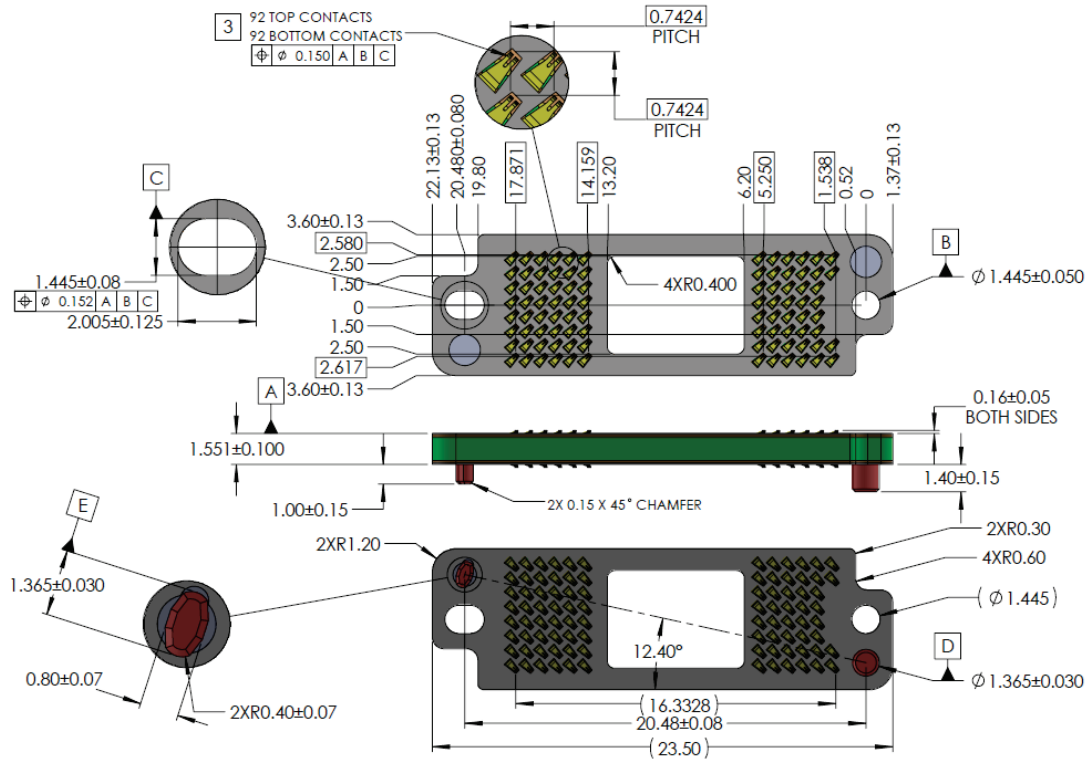
**DIMENSIONAL INFORMATION**

NOTES:(UNLESS OTHERWISE SPECIFIED)

- 1.INTERPRET DRAWING PER ASME Y14.5-94.
- 2.COMPLIANT WITH RoHS DIRECTIVE 2002/95/EC
3. CENTER MARKS OF CONTACT POSITIONS ARE FOR COMPRESSED

 DIMENSIONS ARE IN mm  
 TOLERANCES (unless otherwise specified):

 ANGULAR:  $\pm$  2 degree  
 LINEAR: .X  $\pm$  0.15 [0.06]  
 .XX  $\pm$  0.10 [0.04]  
 .XXX  $\pm$  0.05 [0.02]

Note: This example information is for reference only. Please refer to the latest product drawing.

|                                      |                            |                   |                      |                       |
|--------------------------------------|----------------------------|-------------------|----------------------|-----------------------|
| <b>DOCUMENT NUMBER:</b><br>AS-000029 | <b>REV. C</b><br>3/20/2018 | 92-pin Interposer | <b>AUTHOR:</b><br>WT | <b>Page</b><br>3 of 6 |
|--------------------------------------|----------------------------|-------------------|----------------------|-----------------------|

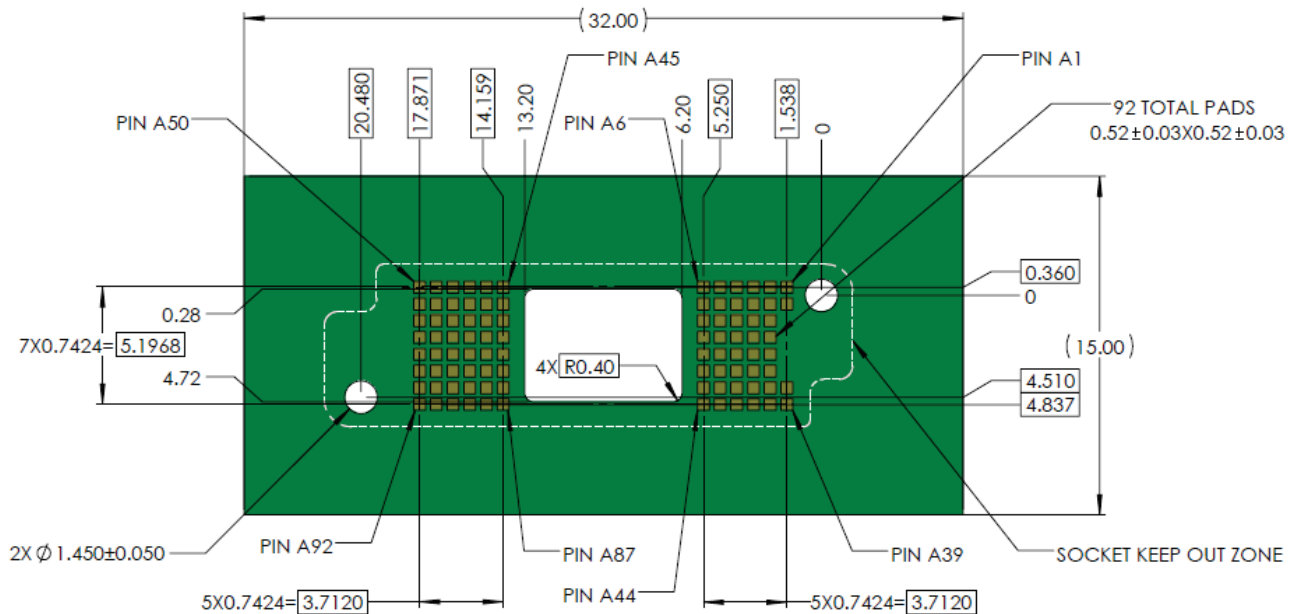
**RECOMMENDED PCB LAYOUT**

**NOTE( UNLESS OTHERWISE SPECIFIED):**

- 1.PADS TO BE ELECTROLESS NICKEL/IMMERSION GOLD (ENIG) PLATED
- 2.VIAS IN PAD AREAS MUST BE FILLED
- 3.INTERPOSER OUTLINE;NO COMPONENTS ALLOWED WITHIN THIS AREA
- 4.ALLOWED COMPONENT AREA; MAXIMUM COMPONENT HEIGHT 1.3 mm
- 5.IF SOLDERMASK IS APPLIED IN THE ARRAY AREA.IT SHALL NOT PROTRUDE ABOVE THE PLANE OF THE CONTACT PAD SURFACE

DIMENSIONS ARE IN mm  
TOLERANCES (unless otherwise specified):

ANGULAR: ± 2 degree  
 LINEAR: .X ± 0.15 [0.06]  
 .XX ± 0.10 [0.04]  
 .XXX ± 0.05 [0.02]

Note: This information is for reference only. Please refer to the latest product drawing.

|                                      |                            |                   |                      |                       |
|--------------------------------------|----------------------------|-------------------|----------------------|-----------------------|
| <b>DOCUMENT NUMBER:</b><br>AS-000029 | <b>REV. C</b><br>3/20/2018 | 92-pin Interposer | <b>AUTHOR:</b><br>WT | <b>Page</b><br>4 of 6 |
|--------------------------------------|----------------------------|-------------------|----------------------|-----------------------|

### ASSEMBLY & HANDLING GUIDELINES

- The use of latex gloves is recommended when handling interposers. As with any normal force connector, avoid touching contact tips and handle the product only by its edges.
- When clamping the module, PCB, or FPC onto the connector, please ensure that the force is applied uniformly. Force should be applied vertically through the z-axis and not in an angled direction.
- Cleaning is typically not needed if the product is kept in original packaging. When necessary, cleaning can be employed with the use of compressed air. Direct the flow of air in the direction that the contact elements are pointing. Cleaning can also be performed with an ultrasonic bath of isopropyl alcohol (IPA). A 5 minute soak can be followed by a 10 minute bake at 65°C.
- When not in use, please keep product stored in original packaging.

### PACKAGING INFO

Production parts are provided in low profile vacuum formed trays. Each tray holds 50 pcs at 60 trays per carton

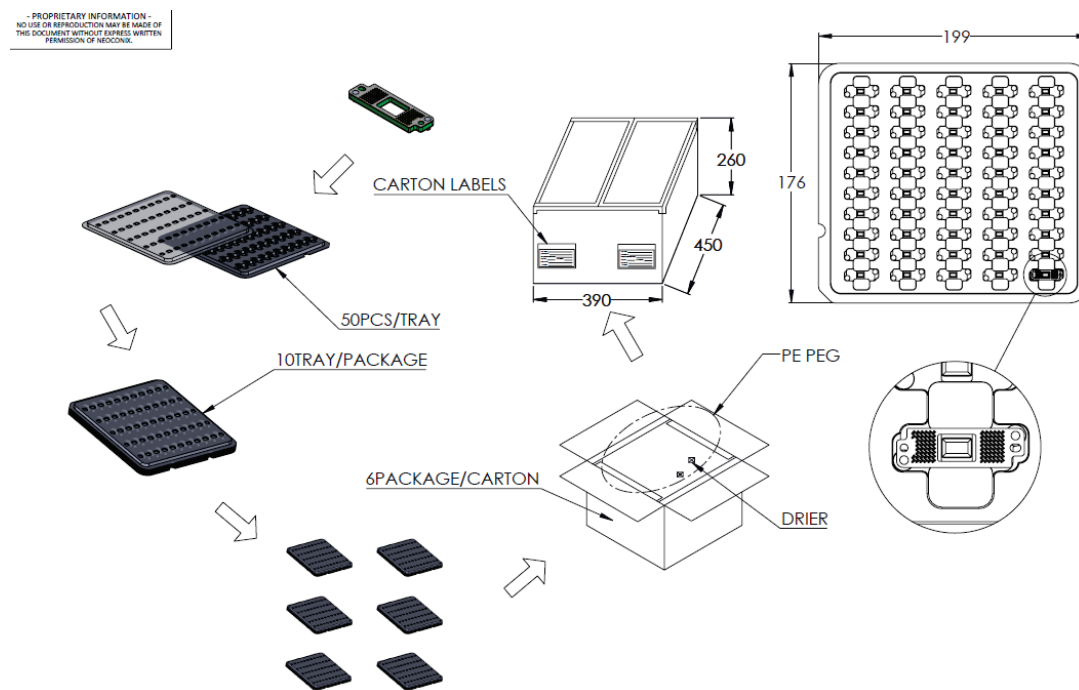

NOTE( UNLESS OTHERWISE SPECIFIED):

1.COMPONENT LOAD PER TRAY : 50PCS

10 TRAY/PACKAGE:500 PCS

6 PACKAGE/CARTON: 450mm X 390mm X 260mm.

TOTAL: 3000PCS/CARTON

2.MATERIAL:TRANSPARENT POLYSTYRENE(PS).

|                                      |                            |                   |                      |                       |
|--------------------------------------|----------------------------|-------------------|----------------------|-----------------------|
| <b>DOCUMENT NUMBER:</b><br>AS-000029 | <b>REV. C</b><br>3/20/2018 | 92-pin Interposer | <b>AUTHOR:</b><br>WT | <b>Page</b><br>5 of 6 |
|--------------------------------------|----------------------------|-------------------|----------------------|-----------------------|



### ORDERING INFO

To obtain a quotation, please contact the Neoconix sales office at [sales@neoconix.com](mailto:sales@neoconix.com) or 408-530-9393. Please include the part number(s) of interest.

Custom interposers and hardware are also available from Neoconix.

**Corporate Headquarters:**

Neoconix, Inc.  
4020 Moorpark Ave., #108  
San Jose, CA 95117 USA

Phone: +1 (408) 530-9393  
Fax: +1 (408) 530-9383  
Email: [sales@neoconix.com](mailto:sales@neoconix.com)  
UR: <http://www.neoconix.com>

China Contact: David Chen  
Phone: +1 (408) 768-4135  
Email: [sales@neoconix.com](mailto:sales@neoconix.com)

### REVISION HISTORY

|       |            |   |
|-------|------------|---|
| Rev A | 08/11/2017 | Production Release                        |
| Rev B | 09/10/2017 | Updated Packaging Info and Ordering Info. |
| Rev C | 03/20/2018 | Updated Packaging Info and Ordering Info. |

|                                      |                            |                   |                      |                       |
|--------------------------------------|----------------------------|-------------------|----------------------|-----------------------|
| <b>DOCUMENT NUMBER:</b><br>AS-000029 | <b>REV. C</b><br>3/20/2018 | 92-pin Interposer | <b>AUTHOR:</b><br>WT | <b>Page</b><br>6 of 6 |
|--------------------------------------|----------------------------|-------------------|----------------------|-----------------------|