

- PROPRIETARY INFORMATION -
NO USE OR REPRODUCTION MAY BE MADE OF
THIS DOCUMENT WITHOUT EXPRESS WRITTEN
PERMISSION OF NEOCONIX.

ITEM NO.	DESCRIPTION	Default/QTY
1	SCREW, WAFERHEAD, M1.4	1
2	STIFFENER	1
3	FLEX	1
4	INTERPOSER	1
5	ALIGNMENT PIN	2
6	PCB	1
7	NUT, CUSTOM SMT, M1.4	1

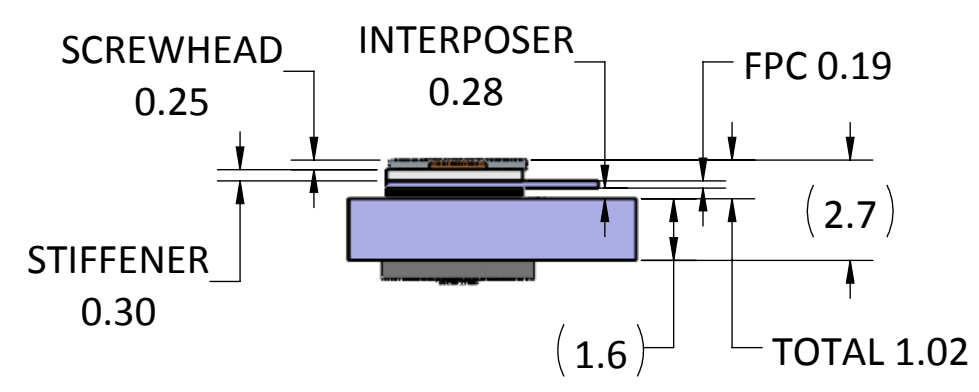
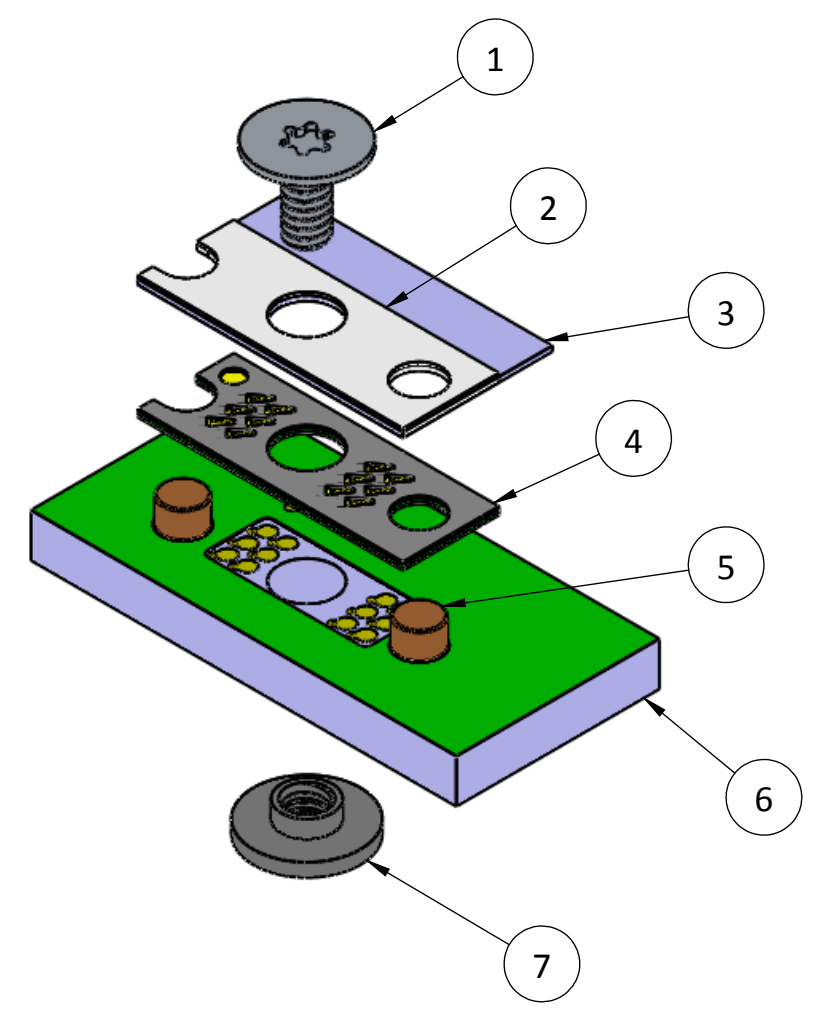
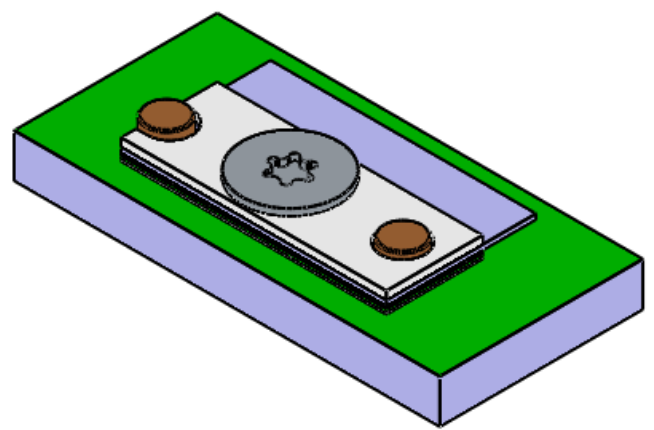
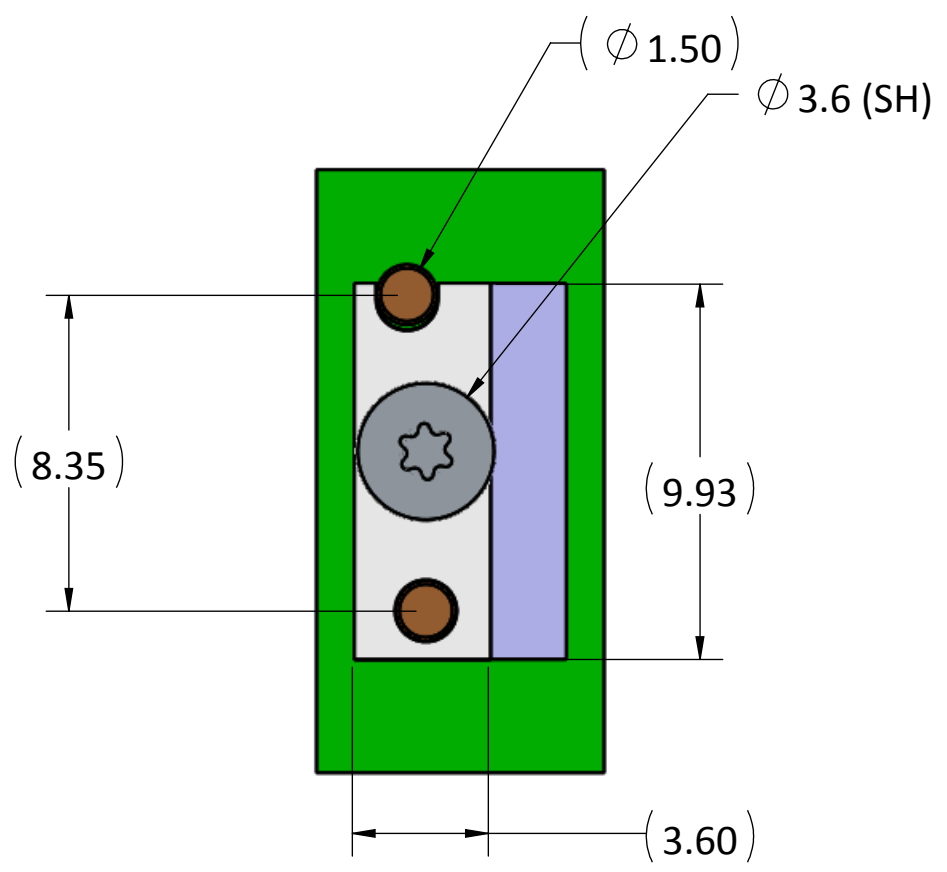

<p>2355-C PARAGON DRIVE. SAN JOSE, CA 95131 TEL: 408-530-9393 FAX: 408-530-9383</p>	DIMENSIONS ARE IN MM [INCH] .X ± .XX ± .XXX ± ANGLE: NO DEC ± .X ± .XX ±	MATERIAL: FINISH: DRAWN BY: JASON WU 03-20-2015 CHECKED BY: ENGR APPR: MFG APPR: QA APPR:	TITLE: INTERPOSER, SCREW-DOWN 12 POSITIONS LGA-LGA DWG NUMBER: LPM-012A-ASY SCALE: 5:1
	THIRD ANGLE	SIZE: B+	REV: 1
	SHEET 1 OF 8		REV: 1
	SHEET 1 OF 8		REV: 1

- PROPRIETARY INFORMATION -
NO USE OR REPRODUCTION MAY BE MADE OF
THIS DOCUMENT WITHOUT EXPRESS WRITTEN
PERMISSION OF NEOCONIX.

REVISIONS				
REV	ECO	DESCRIPTION	DATE	DRAWN BY
1	0000	INITIAL RELEASE	03-20-2015	Jason

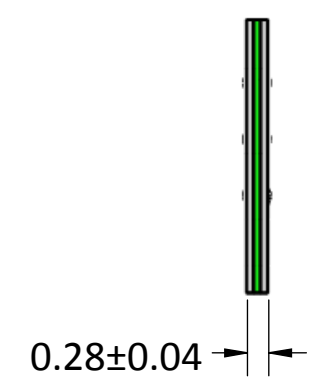
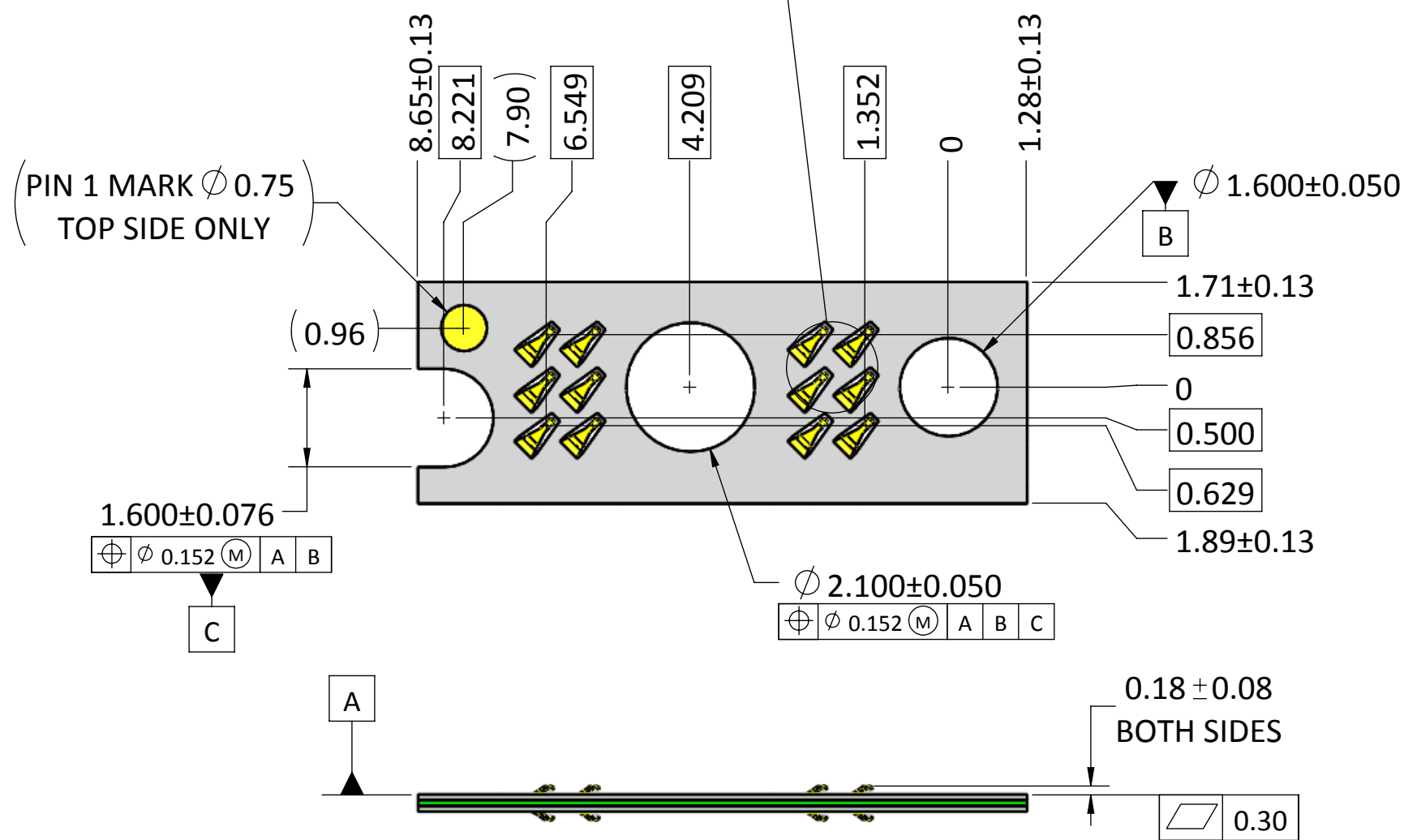
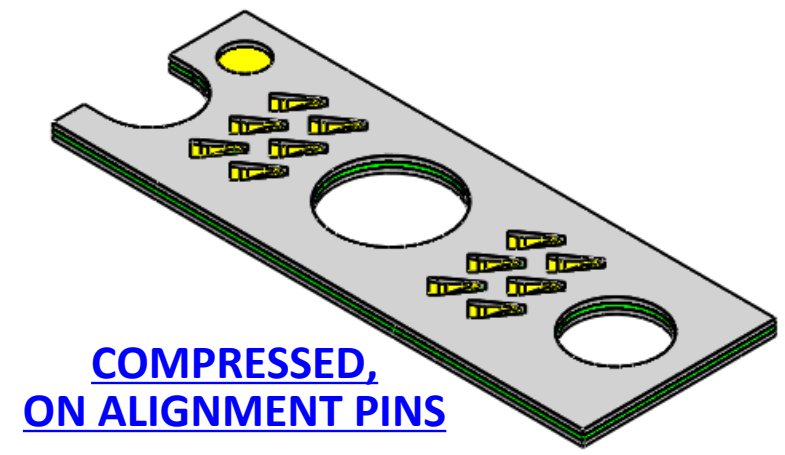
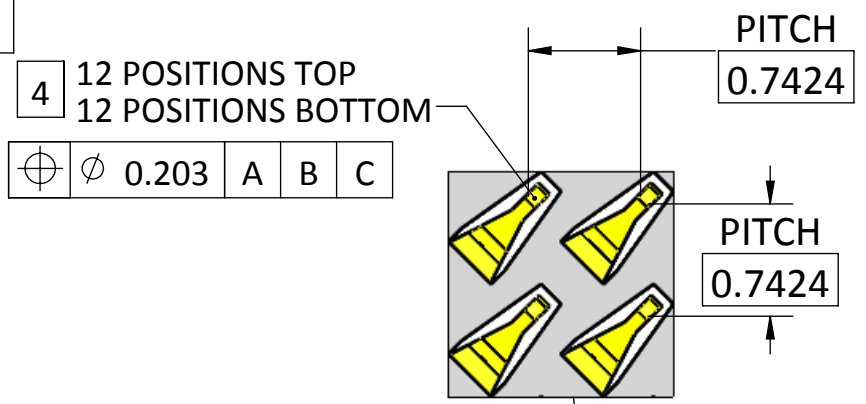

UNCOMPRESSED

NOTES (UNLESS OTHERWISE SPECIFIED):

1. INTERPRET DRAWING PER ASME Y14.5-94.
2. HALOGEN-FREE PER IPC-4101B.
3. COMPLIANT WITH RoHS DIRECTIVE 2011/65/EU.
4. CENTER MARKS OF CONTACT POSITIONS ARE FOR COMPRESSED STATE.

<p>2355-C PARAGON DRIVE. SAN JOSE, CA 95131 TEL: 408-530-9393 FAX: 408-530-9383</p>	<p>DIMENSIONS ARE IN MM [INCH]</p> <p>.X ± 0.13 [.005] .XX ± 0.08 [.003] .XXX ± 0.025 [.001]</p> <p>ANGLE: NO DEC ± 1° .X ± 0.5° .XX ± 0.25°</p>	<p>MATERIAL: SEE NOTES</p> <p>FINISH: SEE NOTES</p>	<p>TITLE: INTERPOSER, SCREW-DOWN 12 POSITIONS LGA-LGA</p>	
	<p>DRAWN BY: Jason Wu 03-20-2015</p> <p>CHECKED BY: Woody Maynard 03-20-2015</p>	<p>SIZE: B+</p>	<p>DWG NUMBER: LPM-012A</p>	<p>REV: 1</p>
	<p>ENGR APPR:</p> <p>MFG APPR:</p> <p>QA APPR:</p>	<p>SCALE: 10:1</p>	<p>SHEET 2 OF 8</p>	
	<p>THIRD ANGLE</p>			

- PROPRIETARY INFORMATION -
NO USE OR REPRODUCTION MAY BE MADE OF
THIS DOCUMENT WITHOUT EXPRESS WRITTEN
PERMISSION OF NEOCONIX.

REVISIONS				
REV	ECN	DESCRIPTION	DATE	APPROVED
1	0000	INITIAL RELEASE	03-20-2015	JASON

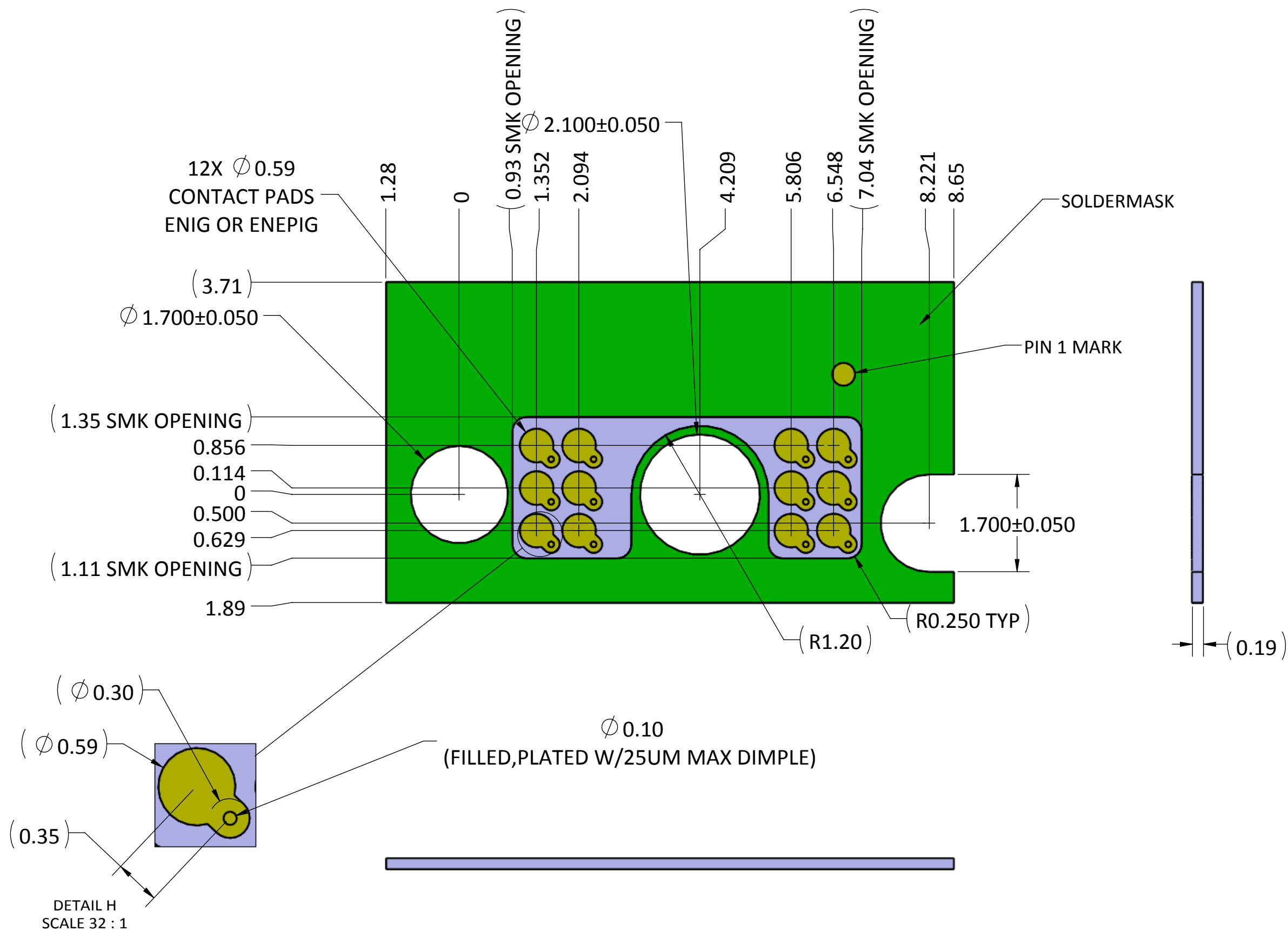

neconix
2355-C PARAGON DRIVE.
SAN JOSE, CA 95131
TEL: 408-530-9393 FAX: 408-530-9383

DIMENSIONS ARE IN
MM [INCH]
.X \pm 0.13 [.005]
.XX \pm 0.08 [.003]
.XXX \pm 0.025 [.001]
ANGLE: NO DEC \pm 1°
.X \pm 0.5°
.XX \pm 0.25°

MATERIAL:
FINISH: ✓
DRAWN BY: JASON WU 03-20-2015
CHECKED BY:
ENGR APPR:
MFG APPR:
QA APPR:

TITLE:
**RECOMMENDED FPC LAYOUT
12 POSITIONS LGA-LGA**

SIZE: B+ DWG NUMBER: LPM-012A-FPC REV: 1

SCALE: 10:1 SHEET 3 OF 8

- PROPRIETARY INFORMATION -
NO USE OR REPRODUCTION MAY BE MADE OF
THIS DOCUMENT WITHOUT EXPRESS WRITTEN
PERMISSION OF NEOCONIX.

REVISIONS				
REV	ECN	DESCRIPTION	DATE	APPROVED
1	0000	INITIAL RELEASE	03-20-2015	JASON

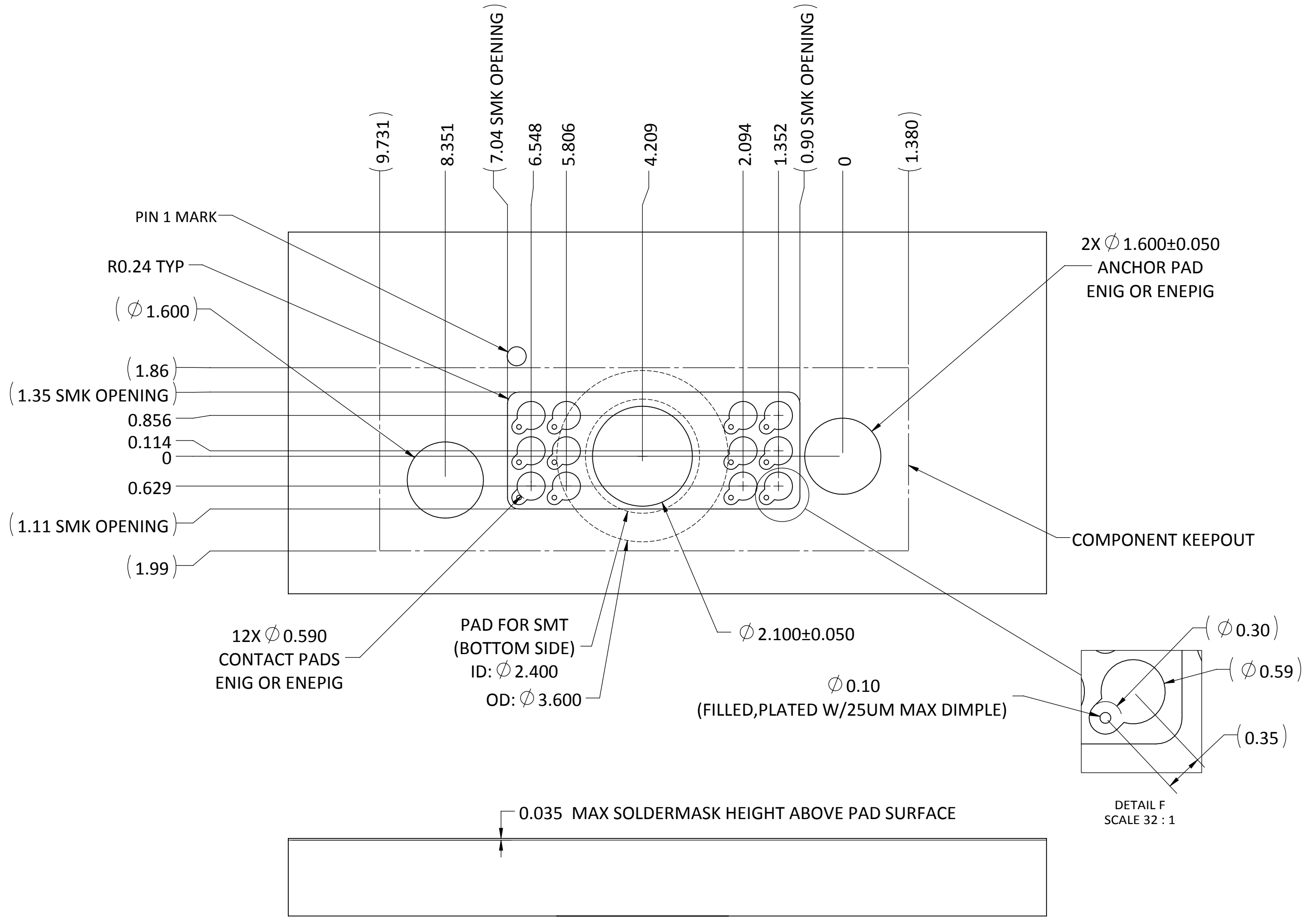

<p>2355-C PARAGON DRIVE. SAN JOSE, CA 95131 TEL: 408-530-9393 FAX: 408-530-9383</p>	<p>DIMENSIONS ARE IN MM [INCH]</p> <p>.X ± 0.13 [.005] .XX ± 0.08 [.003] .XXX ± 0.025 [.001]</p> <p>ANGLE: NO DEC ± 1° .X ± 0.5° .XX ± 0.25°</p>	<p>MATERIAL:</p> <p>FINISH:</p>	<p>TITLE:</p> <p>RECOMMENDED PCB LAYOUT 12 POSITIONS</p>	
	<p>CHECKED BY:</p> <p>ENGR APPR:</p>	<p>DRAWN BY: JASON WU 03-20-2015</p> <p>CHECKED BY:</p> <p>ENGR APPR:</p>	<p>SIZE:</p> <p>B+</p>	<p>DWG NUMBER:</p> <p>LPM-012A-PCB</p>
	<p>MFG APPR:</p> <p>QA APPR:</p>	<p>MFG APPR:</p> <p>QA APPR:</p>	<p>SCALE:</p> <p>10:1</p>	<p>REV</p> <p>1</p>
	<p>THIRD ANGLE</p>		<p>SHEET 4 OF 8</p>	<p>SCALE: 10:1</p>

- PROPRIETARY INFORMATION -
NO USE OR REPRODUCTION MAY BE MADE OF
THIS DOCUMENT WITHOUT EXPRESS WRITTEN
PERMISSION OF NEOCONIX.

REVISIONS			
REV.	DESCRIPTION	DATE	DESIGN BY:
1	INITIAL	09/09/13	TAN
2	REVISE THE PIN LENGHT FROM 0.75 TO 1.0 mm	10/01/13	TAN
3	ADD CTF TO THE DIAMETER	10/28/13	TAN
4	ECN 1120 - ADD CTF TO LENGHT	01/23/14	TAN

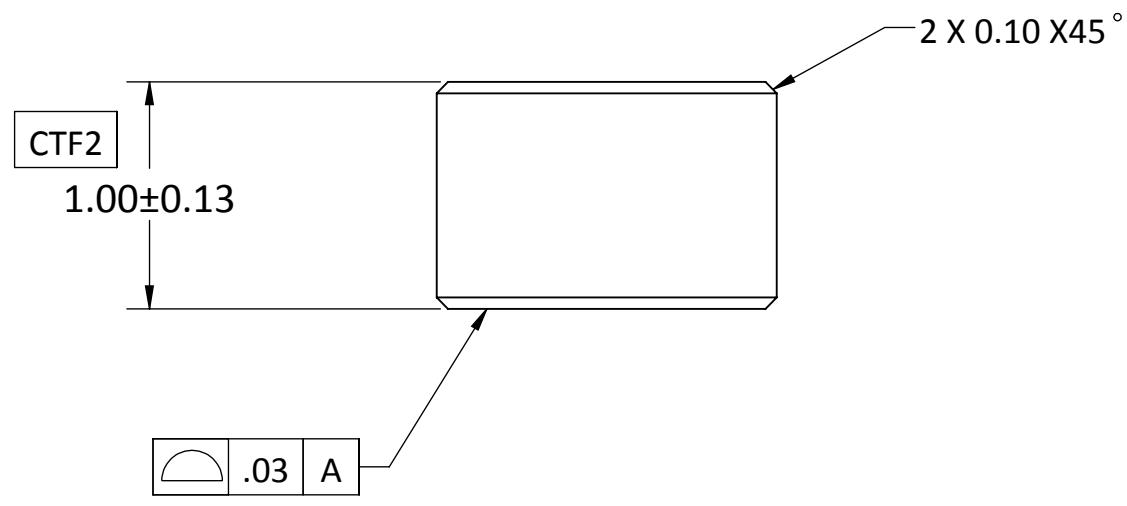
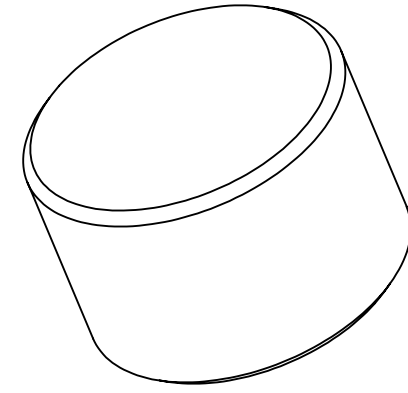
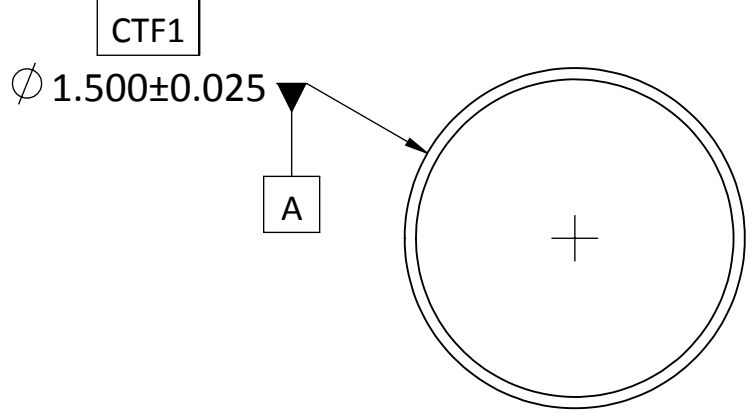

NOTES:(UNLESS OTHERWISE SPECIFIED)

- MATERIAL: C54400 - PHOSPHOR BRONZE.
- PLATE:SULFAMATE NICKEL, 3.5 +/-2.0 um PER ASTM B689-97(2008), + BRIGHT TIN, 5.0+/-2.0 um PER ASTM B545-97(2009).

 715 N. PASTORIA AVE. SUNNYVALE, CA 94085 TEL: 408-530-9393 FAX: 408-530-9372	DIMENSIONS ARE IN MM [INCH] .X ± 0.20 [.008] .XX ± 0.10 [.004] .XXX ± 0.025 [.001] ANGLE: NO DEC ± 1° .X ± 0.5° .XX ± 0.25°	MATERIAL: SEE NOTES FINISH: SEE NOTES DRAWN BY: TAN NGUYEN 09/09/2013 CHECKED BY: W MAYNARD 09/09/2013 ENGR APPR: MFG APPR: QA APPR:	TITLE: ALIGNMENT PIN ($\phi 1.50$ X 1.0 mm LONG) DWG NUMBER: B01-000589
	THIRD ANGLE	SIZE: B+	REV: 4
	SCALE: 12:1		SHEET 5 OF 8
	SHEET 5 OF 8		

- PROPRIETARY INFORMATION -
NO USE OR REPRODUCTION MAY BE MADE OF
THIS DOCUMENT WITHOUT EXPRESS WRITTEN
PERMISSION OF NEOCONIX.

REVISIONS				
REV	ECO	DESCRIPTION	DATE	APPROVED
0	0000	INITIAL RELEASE	03-20-2015	JASON

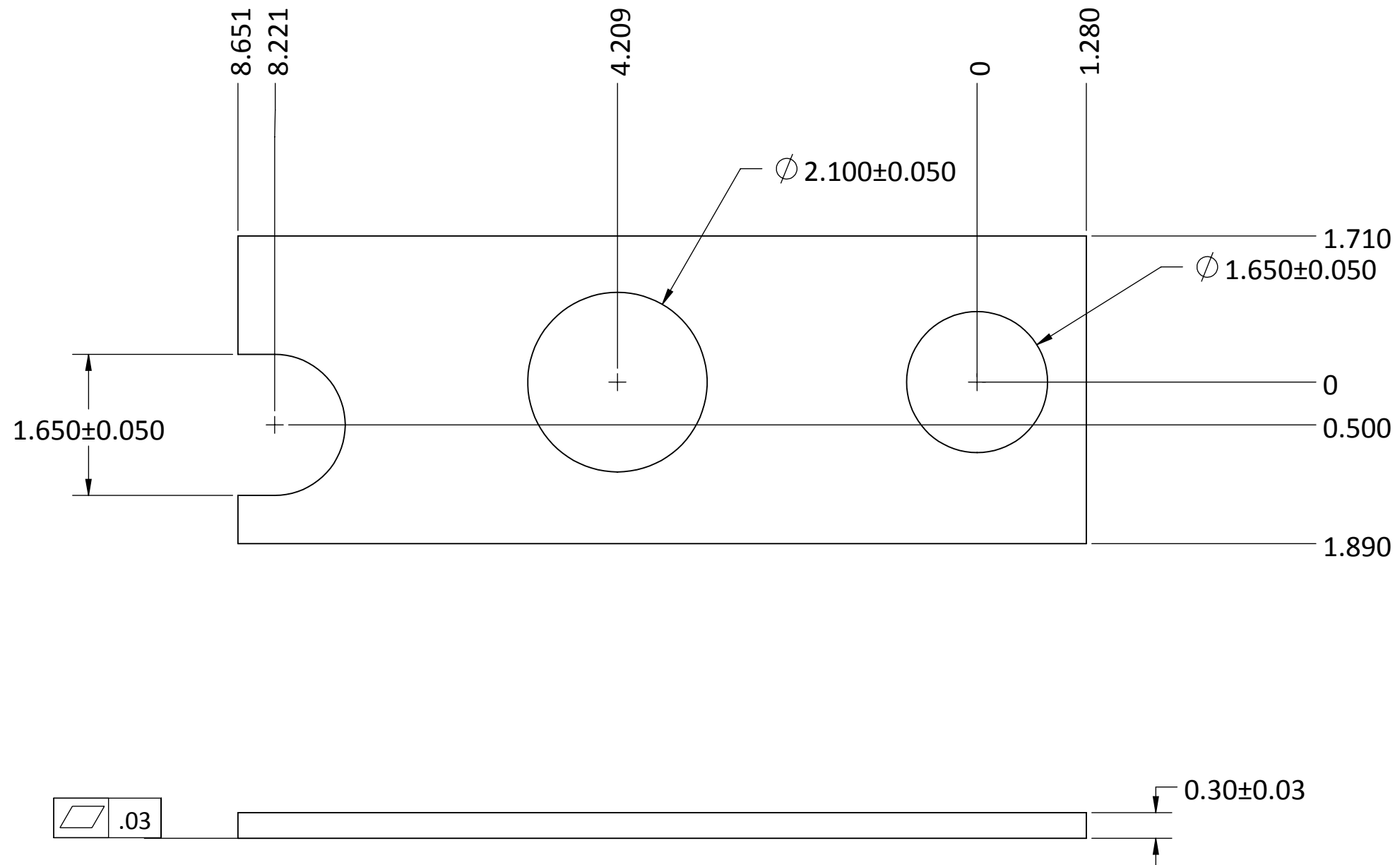

NOTES (UNLESS OTHERWISE SPECIFIED):

1. INTERPRET DRAWING PER ASME Y14.5-94.



2355-C PARAGON DRIVE.
SAN JOSE, CA 95131
TEL: 408-530-9393 FAX: 408-530-9383

DIMENSIONS ARE IN
MM [INCH]
.X ± 0.13 [.005]
.XX ± 0.08 [.003]
.XXX ± 0.025 [.001]
ANGLE: NO DEC ± 1°
.X ± 0.5°
.XX ± 0.25°
THIRD ANGLE

MATERIAL: 301 SS FULL HARD
FINISH: SEE NOTES
DRAWN BY: JASON WU 03-20-2015
CHECKED BY:
ENGR APPR:
MFG APPR:
QA APPR:

TITLE: STIFFENER, MB 12 POS
DWG NUMBER: LPM-012A-STF
SCALE: 10:1
SHEET 6 OF 8

REV 1

- PROPRIETARY INFORMATION -
NO USE OR REPRODUCTION MAY BE MADE OF
THIS DOCUMENT WITHOUT EXPRESS WRITTEN
PERMISSION OF NEOCONIX.

REVISIONS				
ZONE	REV.	DESCRIPTION	DATE	APPROVED
	1	INITIAL PRODUCTION RELEASE	08-12-2014	TAN

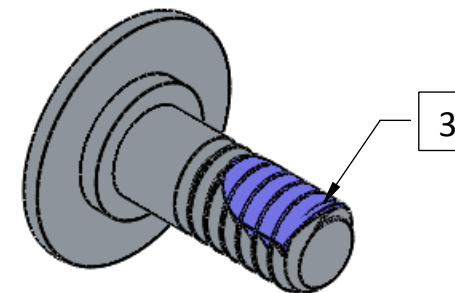
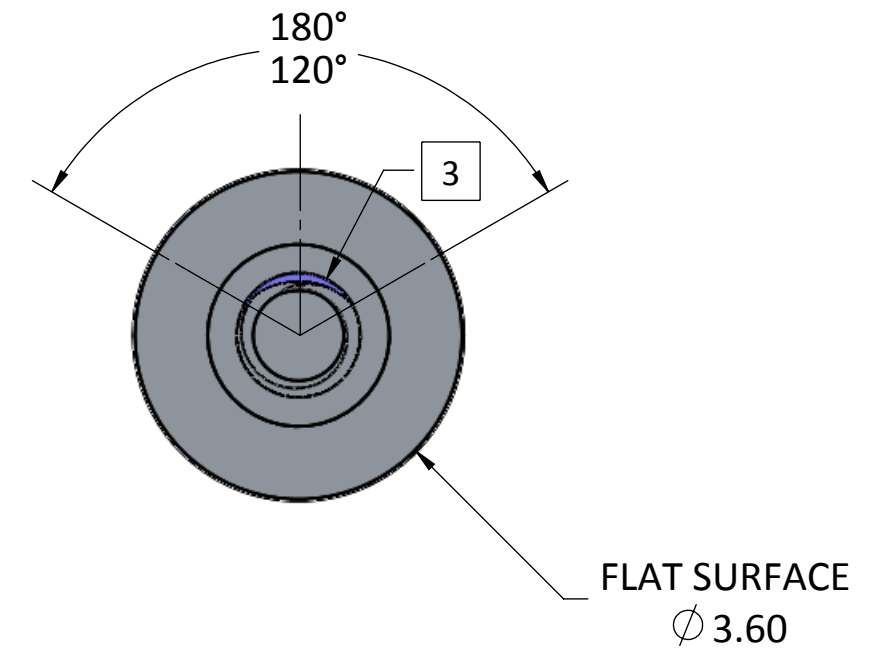
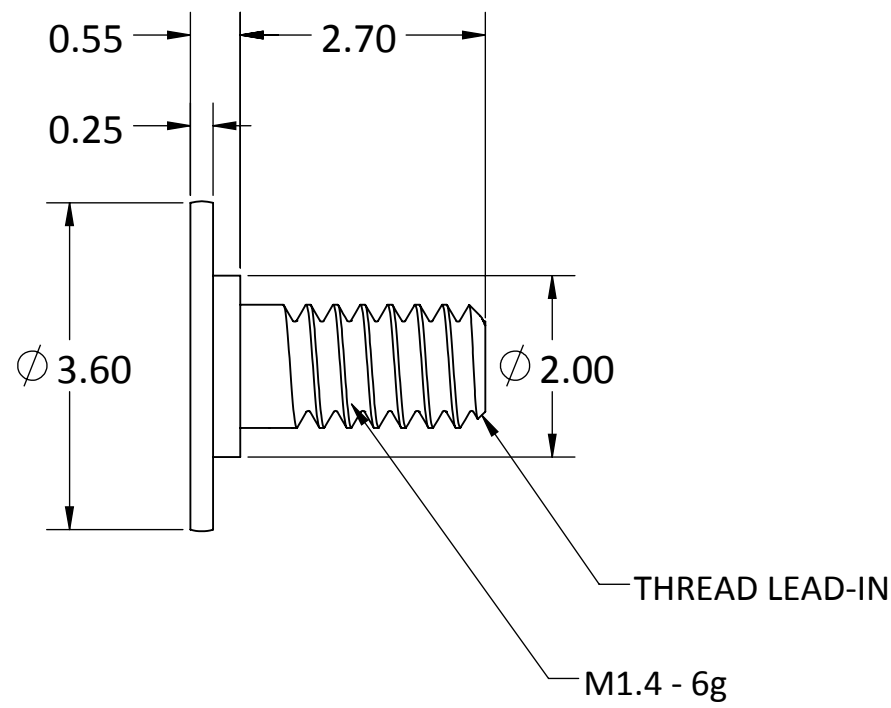
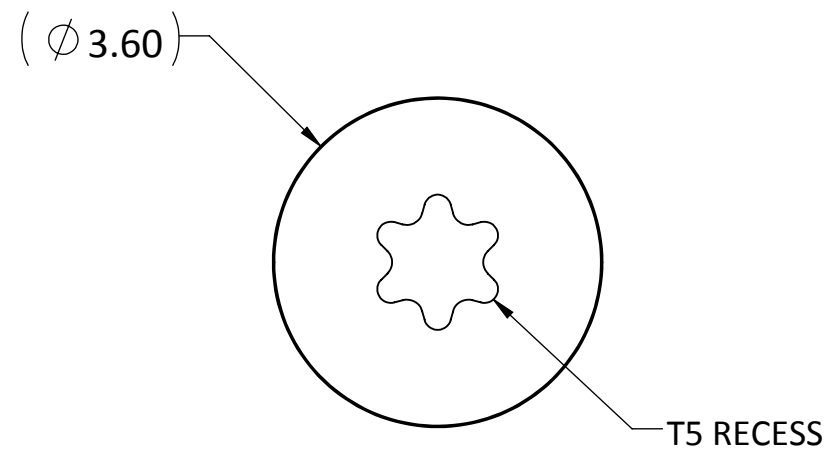

NOTES:

1. MATERIAL: AISI 1018
2. FINISH: BRIGHT NICKEL PER ASTM B689-97, TYPE 2, CLASS 5
3. THREADLOCK: NYLOK-BLUE, FIRST 4-6 WHOLE THREADS, 120°-180° COVERAGE.
4. SCREW FIT TOLERANCE DOES NOT INCLUDE THREADLOCK.
5. PART TO BE FREE OF BURRS AND SHARP EDGES.

PART NUMBER: B01-000614

<p>2355-C PARAGON DRIVE. SAN JOSE, CA 95131 TEL: 408-530-9393 FAX: 408-530-9383</p>	DIMENSIONS ARE IN MM [INCH] .X ± 0.13 [.005] .XX ± 0.08 [.003] .XXX ± 0.025 [.001] ANGLE: NO DEC ± 1° .X ± 0.5° .XX ± 0.25°		MATERIAL: SEE NOTES FINISH: SEE NOTES		TITLE: SCREW, M1.4 X 3.05mm LG	
	DRAWN BY: TAN NGUYEN 08-12-2014		CHECKED BY:		SIZE B+	DWG NUMBER: B01-000614
	ENGR APPR:		MFG APPR:		REV 1	
	QA APPR:		THIRD ANGLE		SCALE: 12:1 SHEET 7 OF 8	

- PROPRIETARY INFORMATION -
NO USE OR REPRODUCTION MAY BE MADE OF
THIS DOCUMENT WITHOUT EXPRESS WRITTEN
PERMISSION OF NEOCONIX.

REVISIONS				
REV.	ECN NO.	DESCRIPTION	DATE	APPROVED
A	0000	INITIAL PRODUCTION RELEASE	SEP. 10 2013	Liyin Lee
B	0000	Change nut length	SEP. 23 2013	Liyin Lee
C	1106	ADD NOTE # 4	NOV. 19 2013	TAN

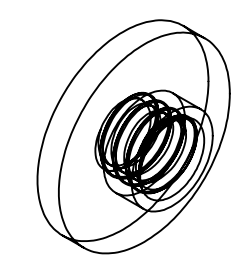
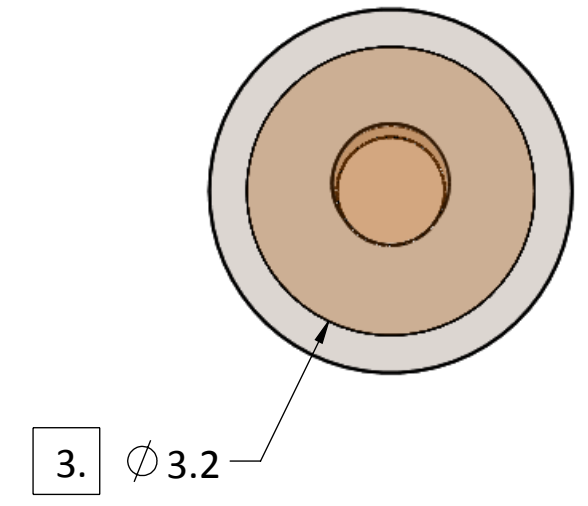
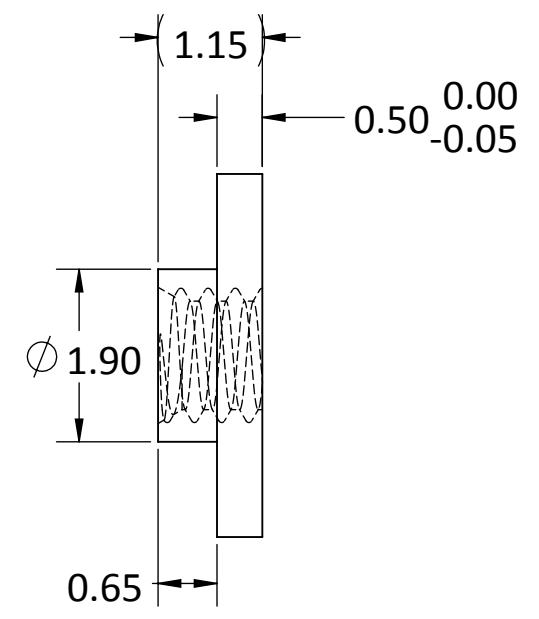
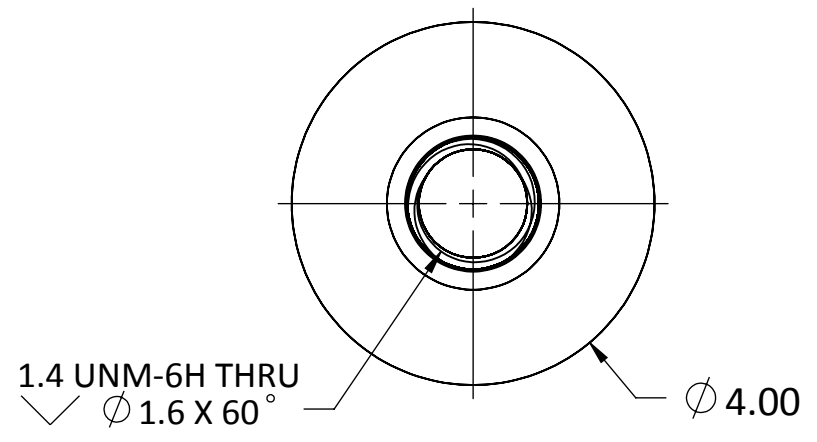

NOTES:

- MATERIAL: FREE-MACHINING BRONZE, UNS C54400 H04 TEMPER (UTS 450 MPa MIN)
- PART TO BE FREE OF BURRS AND SHARP EDGES.
- HI-TEMP POLYIMIDE TAPE, 260 °C [500 °F] MINIMUM
TOTAL THICKNESS .025-.076 MM [.001-.003 IN]
ADHESION TO STEEL 27 N/100 MM [25 OZ/IN] MINIMUM, PER ASTM D 3330 (OR EQUIV)
- PLATE: SULFAMATE NICKEL, 3.5 +/-2.0 um PER ASTM B689-97 (2008),
+ BRIGHT TIN, 5.0 +/-2.0 um PER ASTM B545-97 (2009).

PART NUMBER: B01-000581

<p>715 N. PASTORIA AVE. SUNNYVALE, CA 94085 TEL: 408-530-9393 FAX: 408-530-9372</p>	<p>DIMENSIONS ARE IN MM [INCH]</p> <p>.X ± 0.13 [.005] .XX ± 0.08 [.003] .XXX ± 0.025 [.001]</p> <p>ANGLE: NO DEC ± 1° .X ± 0.5° .XX ± 0.25°</p>	<p>MATERIAL: SEE NOTES</p> <p>FINISH: SEE NOTES</p>	<p>TITLE: NUT, M1.4 X 1.15mm LG</p>	
	<p>THIRD ANGLE</p>	<p>DRAWN BY: TAN NGUYEN 08-19-2013</p> <p>CHECKED BY: W MAYNARD 08-19-2013</p> <p>ENGR APPR:</p> <p>MFG APPR:</p> <p>QA APPR:</p>	<p>SIZE: B+</p>	<p>DWG NUMBER: B01-000581</p>
	<p>SCALE: 12:1</p>	<p>SHEET 8 OF 8</p>	<p>REV: C</p>	